

## THE IMPLEMENTATION OF IOT & SMS BASED SMART REFRIGERATOR

Dr. V. RADHIKA<sup>1</sup>, CH. LAKSHMI SAI SANJANA<sup>2</sup>, A.V.N.S. JAYANTH<sup>3</sup>

<sup>1</sup>Associate Professor, Dept. of ECE, PRAGATI ENGINEERING COLLEGE

<sup>23</sup>UG Students, Dept. of ECE, PRAGATI ENGINEERING COLLEGE

### ABSTRACT

Wasted food due to spoilage is a critical resource issue. Food waste or food loss is food that is discarded or lost uneaten. Currently, in the world, according to the Food and Agriculture Organization of the United Nations (FAO), consumers waste about 1.3 billion tons of food annually and consumers in rich countries waste about 222 million tons of food products. Once food products are purchased and set aside in a refrigerator, the users do not alert about their food items' expiration date and/or freshness unless they individually examine and track them. Moreover, for food products which are not labelled with an explicit expiration date may lead to significant food spoilage and additional expenditure for the users. However, with the latest trend technology of the Internet of Things (IoT), this problem can be resolved. Combining the idea of Internet of Things and smart kitchen evolution, the smart refrigerator system is developed. The system consists of three main parts which are sensing module, control module and transmission module. Sensing module consists of DHT11 and odour sensor while control module consists of Arduino UNO and power supply unit and last but not least, the transmission module consists of LCD module and Wi-Fi module. These modules work together to determine contents status inside the refrigerator and notify the user about the condition and quantity of the food via an SMS.

### INTRODUCTION

The Implementation of IoT & SMS Based Smart Refrigerator project introduces a transformative approach to conventional refrigeration technology. By integrating IoT sensors and SMS-based communication, this project aims to enhance the functionality and convenience of household refrigerators. Through the utilization of temperature, humidity, and weight sensors, the smart refrigerator ensures precise monitoring and control of food storage conditions. Users can remotely access and manage the refrigerator's operations via a dedicated mobile application or SMS commands, offering unprecedented convenience. Automated alerts

notify users of any deviations from optimal conditions, promoting food safety and minimizing wastage.

The project emphasizes energy efficiency through intelligent algorithms, optimizing cooling cycles to reduce electricity consumption. By bridging the gap between traditional appliances and modern technology, the smart refrigerator exemplifies the potential of IoT in everyday life. Accessibility is ensured through Wi-Fi or Ethernet connectivity, enabling seamless integration into smart home ecosystems. Real-time data from IoT sensors enables proactive maintenance and troubleshooting, enhancing reliability. The project addresses key challenges in traditional refrigeration, such as manual monitoring and limited control. Through remote monitoring and management capabilities, users can optimize food storage and reduce their environmental footprint.

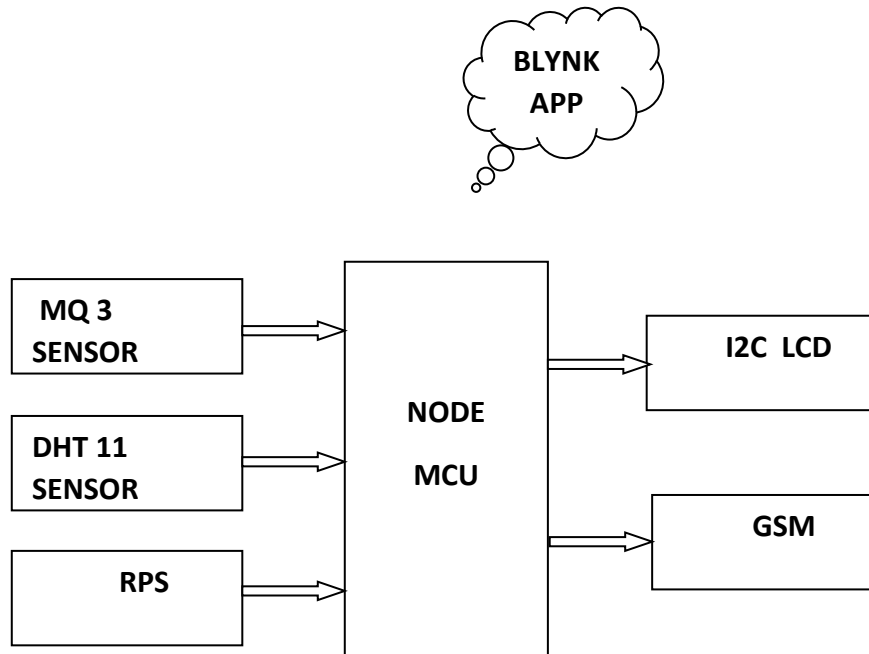

Figure.1 Block Diagram

### LITERATURE SURVEY

1. The first refrigerator connected to the Internet called Quantified Fridge was in a wired 100-year-old house in the Netherlands by Alex van Es in July 12, 1998; where it existed alongside networked lights, doorbell, mailbox, and, a toilet. There is a record and broadcast every time the fridge door opens.

2. In 2002, the Whirlpool's refrigerator transforms into a multimedia communications centre such that the owner can surf the Internet, receive emails, listen to the radio, watch TV, video and DVDs and even talk on the phone.

3. By the late 1990s and the early 2000s, the idea of connecting home appliances to the internet (Internet of Things) had been popularized and was seen as the next big thing. In June 2000, LG launched the world's first internet refrigerator, the Internet Digital DIOS. Internet refrigerator (also known as Smart refrigerator) is a refrigerator which has been programmed to sense what kinds of products are being stored inside it and keep a track of the stock through barcode or RFID scanning.

### PROPOSED SYSTEM

The project emphasizes energy efficiency through intelligent algorithms, optimizing cooling cycles to reduce electricity consumption. By bridging the gap between traditional appliances and modern technology, the smart refrigerator exemplifies the potential of IoT in everyday life. Accessibility is ensured through Wi-Fi or Ethernet connectivity, enabling seamless integration into smart home ecosystems. Real-time data from IoT sensors enables proactive maintenance and troubleshooting, enhancing reliability. The project addresses key challenges in traditional refrigeration, such as manual monitoring and limited control. Through remote monitoring and management capabilities, users can optimize food storage and reduce their environmental footprint. The Implementation of IoT & SMS Based Smart Refrigerator project represents a significant advancement in household appliance innovation.

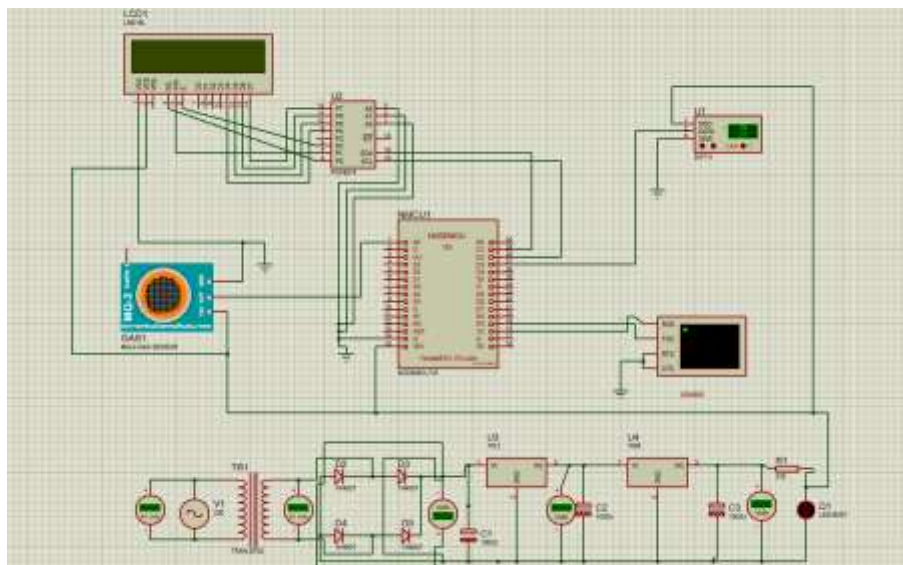

Figure.2 Schematic Diagram

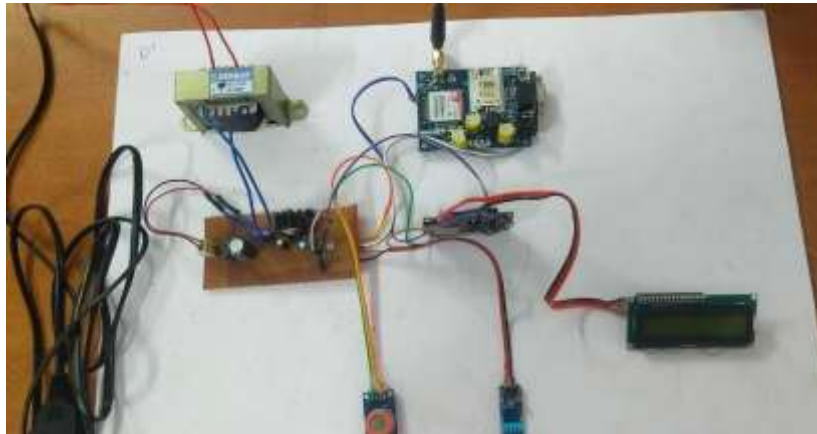

Figure.3 Project Setup

## RESULTS

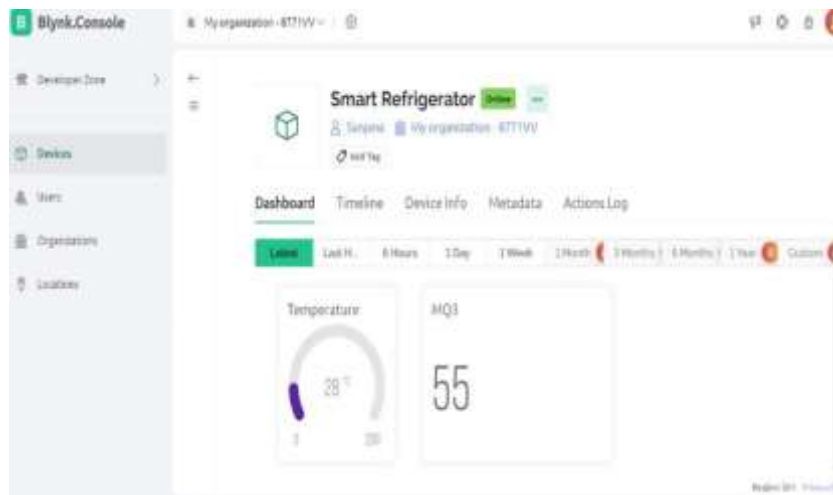

Figure.4 Blynk Output

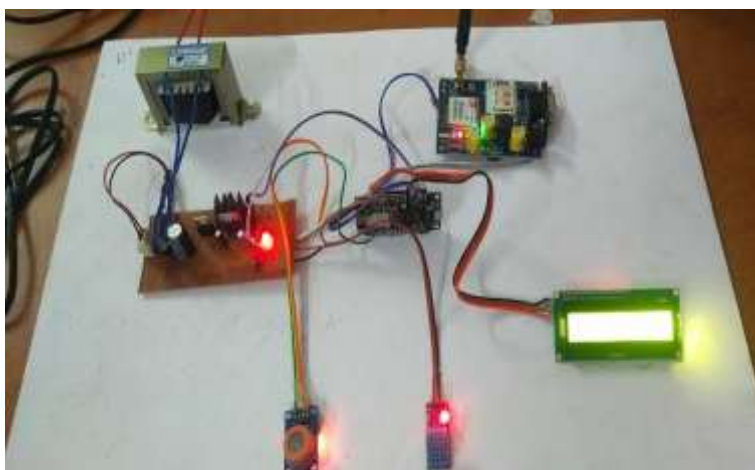

Figure.5 Working Kit



figure.6 Values on LCD



figure.7 Welcomedisplay on LCD

## APPLICATIONS

**Residential Use :** Users can remotely monitor and control their refrigerator, check inventory, and receive alerts about temperature fluctuations

**Commercial Settings :** Facilitates real-time monitoring of perishable goods, enabling store managers to ensure product freshness, reduce spoilage, and improve customer satisfaction.

**Health care facilities :** Provides a reliable solution for storing vaccines, medications, and other temperature-sensitive medical supplies, with remote monitoring capabilities for staff to ensure compliance with storage requirements.

**Research Laboratories :** Offers a controlled environment for storing biological samples, reagents, and laboratory materials, with real-time monitoring and alerting functionalities to safeguard valuable research assets.

**Hospitality Industry :** Enables hotel staff to monitor mini-bars and room service refrigerators, ensuring timely restocking and maintaining guest satisfaction.

## ADVANTAGES

**Remote monitoring:** Users can remotely monitor and control the refrigerator's temperature and inventory status from anywhere using their mobile phones, enhancing convenience and flexibility.

**Real-time Alerts and Notifications :** The system sends real-time alerts and notifications via SMS in case of temperature deviations, low inventory, or power outages, enabling timely intervention to prevent food spoilage.

**User-friendly Interface:** The web or mobile application provides a user-friendly interface for accessing refrigerator status, managing inventory, and receiving alerts, making it easy for users to interact with the system.

**Improved Food Safety:** Continuous monitoring of temperature ensures that perishable food items are stored at optimal conditions, reducing the risk of bacterial growth, foodborne illnesses, and spoilage.

**Energy Efficiency:** Smart control features optimize energy consumption by regulating temperature settings based on usage patterns and environmental conditions, resulting in lower electricity bills and reduced environmental impact

## CONCLUSION

In conclusion, the "Implementation of IoT and SMS-based Smart Refrigerator System" project represents a significant advancement in modern refrigeration technology. By integrating Internet of Things (IoT) sensors and SMS communication, the system offers real-time monitoring of refrigerator temperature, inventory management, and remote control capabilities.

Throughout the project, meticulous attention was given to system design, component selection, and implementation steps to ensure functionality, reliability, and user-friendliness. The literature survey provided valuable insights into existing research, guiding the development process and contributing to the project's success.

The smart refrigerator system demonstrates the potential to enhance food safety, optimize energy efficiency, and improve user convenience in various settings including homes, restaurants, and supermarkets. With the inclusion of future enhancements such as predictive maintenance and voice control integration, the system is poised for further innovation and adoption in the IoT ecosystem.

#### **FUTURE SCOPE**

**Fisheries Storage facilities:** Enhance the IoT-based refrigeration system to provide precise temperature monitoring and control within fisheries storage facilities.

Implement advanced sensors and actuators to maintain optimal storage conditions for various seafood products, ensuring freshness and prolonging shelf life.

**Enhanced User Interface:** Develop a more intuitive and interactive user interface by implementing voice-controlled commands for hands-free operation, enabling users to interact with the refrigerator system using natural language.

**Predictive Maintenance:** Implement self-diagnostic capabilities within the system to automatically detect and troubleshoot common issues, minimizing downtime and service disruptions.

**Food Distribution Networks:** Integrate IoT-enabled refrigeration systems into food distribution networks to ensure the safe transport and storage of perishable goods during transit.

The future scope of the "Implementation of IoT and SMS-based Refrigerator System" project encompasses a wide range of potential advancements and innovations, paving the way for continued development and evolution in the field of smart refrigeration technology. By leveraging emerging technologies and addressing evolving user needs, the project has the

potential to make a significant impact on food safety, energy efficiency, and user convenience in both residential and commercial settings.

## **REFERENCES**

1. IEEE, The Institute, “Special Report: The Internet of Things.” <http://theinstitute.ieee.org/static/specialreport-the-internet-of-things>.
2. Suhuai Luo, Jesse S. Jin, and Jiaming Li, “A Smart Fridge with an Ability to Enhance Health and Enable Better Nutrition” published in International Journal of Multimedia and Ubiquitous Engineering Vol. 4, No. 2, April, 2009.
3. Perumal T, Sulaiman, Musthapa, Shahi A, “Proactive Architecture for Internet of Things (IoTs)”, published in 2014 IEEE 3rd Global Conference on Consumer Electronics (GCCE), 7-10 Oct. 2014.
4. Y Zhai, Y Liu, M Yang, F Long, J Virkki, “A Survey Study of the Usefulness and Concerns about Smart Home Applications” Open Journal of Social Sciences Vol.02 No.11(2014), Article ID:51898, 7 pages 10.4236/jss.2014.211017 .
5. Alolayan Bushra (2014). Do I Really Have to Accept Smart Fridges? An empirical study. In the Proceedings of the Seventh International Conference on Advances in Computer-Human Interactions (ACHI 2014) pp186-191.