

## SMART WATER METER USING IOT

Ms. G. VIRANYA<sup>1</sup>, K. LAKSHMI SOWJANYA<sup>2</sup>, K. SRI SATYA SOWJANYA<sup>3</sup>

<sup>1</sup>Assistant Professor, Dept. of ECE, PRAGATI ENGINEERING COLLEGE

<sup>2,3</sup>UG Students, Dept. of ECE, PRAGATI ENGINEERING COLLEGE

### ABSTRACT

The expanded living spaces requires more quality water distribution administration framework due to the increased living spaces in rural and urban areas. In order to achieve rise to amount of water conveyance to all of the natural surrounds, it is thus essential to design a planned water supply framework. Internet of things, another idea is the envisaged framework for controlled water circulation and defect identification. The key idea of this study is to provide a costeffective framework to achieve better water supply by routinely monitoring and furthermore controlling it from a central server to avoid issues with the water supply to the habitats. The suggested design makes use of solenoid valve, water flow sensor, water level sensor (Ultrasonic Sensor). The valve controlled by an NodeMCU board from IoT platform like BLYNK app. The water flow sensor reads the flow of water in terms of lt/hr and display it on IoT platform. Water level sensor continuously monitors main tank water level and update the data to IoT platform. With level of water in tank, user can switch ON solenoid valve to flow water to house. The flow sensor reads the flow of water and update IoT Platform. The proposed design addresses the issues of overflow, overuse, water acquisition, and distribution in an acceptable manner.

### INTRODUCTION

Water scarcity and the need for efficient water resource management have become critical global challenges. In this context, the integration of smart technologies is pivotal to monitor and manage water consumption effectively. The Smart Water Meter Reading System is a comprehensive project designed to address these challenges by leveraging advanced technology to monitor, analyze, and optimize water usage.

Water scarcity is a pressing issue worldwide, exacerbated by population growth, climate change, and inefficient water management practices. Traditional water metering systems often suffer from limitations such as manual reading errors, delayed billing cycles, and difficulty in identifying leaks promptly. The Smart Water Meter Reading System aims to overcome these

challenges by introducing an innovative solution that combines IoT (Internet of Things) technology with data analytics.

The Key Features are Smart Meters: Install smart water meters equipped with IoT sensors to gather consumption data continuously, Wireless Connectivity: Implement wireless communication protocols (e.g., IoT protocols, LPWAN) for seamless data transmission between meters and the central monitoring system, Data Security: Prioritize data security through encryption and secure communication protocols to protect consumer information and prevent unauthorized access, User Interface: Develop an intuitive user interface accessible through web or mobile applications, enabling consumers to monitor their water usage, receive alerts, and access personalized recommendations

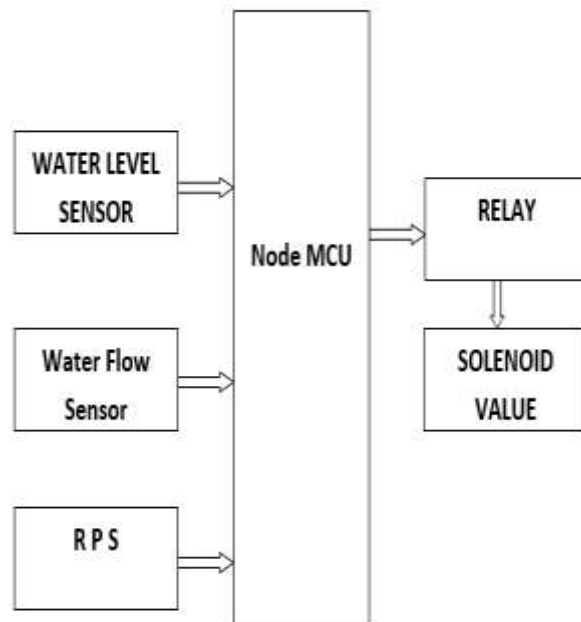

Figure.1 Block diagram

## LITERATURE SURVEY

### Introduction to IoT in Smart Water Metering:

Start with an overview of the role of IoT in smart water metering, emphasizing the importance of real-time monitoring, accurate measurement, and efficient management of water resources.

Explore literature discussing the challenges faced by traditional water metering systems and the potential benefits of integrating IoT capabilities into water infrastructure.

**Design and Architecture of IoT-Based Smart Water Meters:**

Investigate research papers and articles that discuss the design principles and architecture of IoT-based smart water meters.

Look for studies that describe the integration of sensors, communication modules, microcontrollers, and cloud platforms to enable remote monitoring, data collection, and analytics.

**Sensor Technologies for Water Measurement:**

Review literature on sensor technologies used in IoT-based smart water meters for accurate measurement of water consumption.

Explore studies that discuss the deployment of flow sensors, pressure sensors, ultrasonic sensors, or electromagnetic sensors to monitor water flow rates and detect leaks or anomalies.

**Data Collection and Transmission:**

Examine research papers and articles that discuss data collection and transmission mechanisms in IoT-based smart water meters.

Look for studies that describe how sensor data is collected, processed, and transmitted to central databases or cloud servers using wireless communication protocols such as Wi-Fi, LoRaWAN, NB-IoT, or Sigfox.

**Cloud Platforms for Data Storage and Analysis:**

Investigate literature on cloud platforms used for data storage and analysis in IoT-based smart water metering systems.

Explore studies that discuss the integration of cloud services such as AWS IoT, Microsoft Azure IoT, Google Cloud IoT, or IBM Watson IoT for storing meter data, running analytics algorithms, and generating insights.

**Leak Detection and Anomaly Detection Algorithms:**

Review research papers and articles that discuss leak detection and anomaly detection algorithms used in IoT-based smart water metering systems.

Explore studies that describe signal processing methods, machine learning algorithms, and pattern recognition techniques for identifying water leaks, abnormal usage patterns, or metering errors.

### PROPOSED SYSTEM

The Smart Water Meter is used to Monitor the Flow of Water and Level of Water, Additionally Solenoid Valve Turnoff When it reaches the Certain Level as Mentioned by User. The water flow sensor monitors the flow of water, providing real-time data on consumption. The water level sensor measures the water level in a tank or reservoir.

Node MCU gathers data from these sensors and can send it to a central server or cloud platform for further processing and analysis. Depending on the water level and flow data, the Node MCU can control the solenoid valve through the relay to manage the water supply.

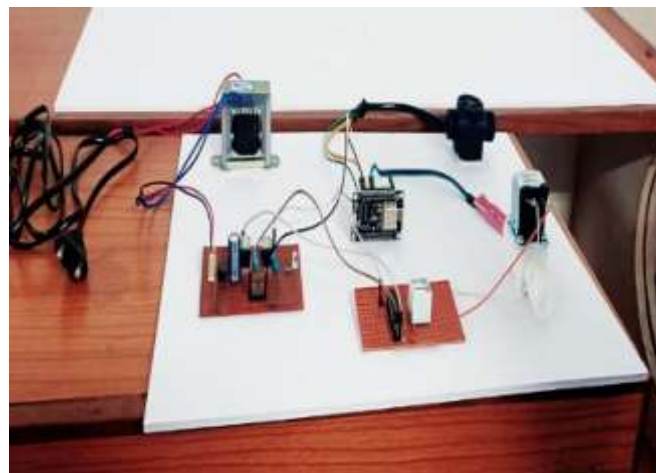

Figure.1 Working kit

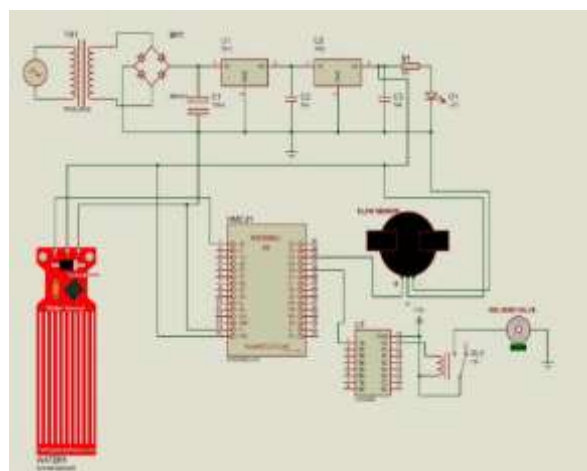

Figure.3 Schematic diagram

## RESULT

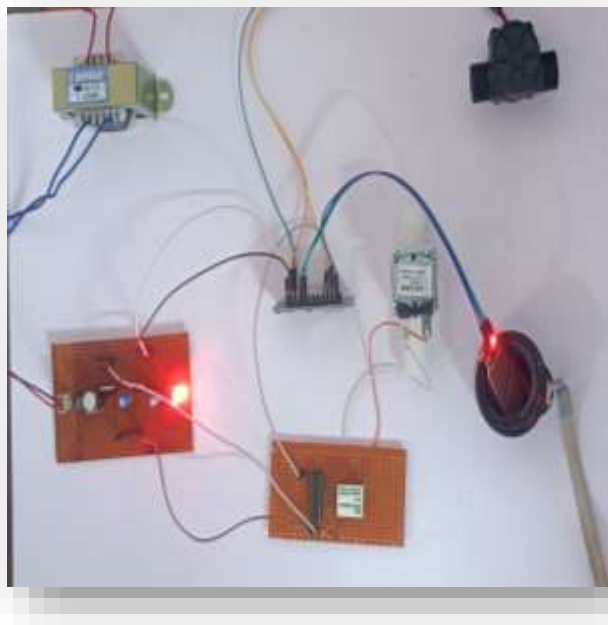

Figure.4 Water level measurement



figure.5 Status on the Blynk

## APPLICATIONS

A smart water meter reading project can offer several benefits and applications across various sectors. Here are some potential applications:

**Efficient Water Management:** Water Conservation: Real-time monitoring and accurate data collection enable better management of water resources, leading to more efficient water usage and conservation efforts.

**Leak Detection:** The system can identify leaks promptly, preventing water wastage and minimizing damage to infrastructure.

**Automated Billing:** Smart meters allow for automated and accurate billing based on actual water consumption, reducing the likelihood of errors and disputes.

**Consumption Awareness:** Consumers can access real-time data about their water usage, encouraging responsible water consumption habits.

**Reduced Energy Consumption:** By optimizing water distribution and reducing leakages, the energy required for water treatment and distribution can be minimized, contributing to environmental sustainability.

## ADVANTAGES

**Real-time Monitoring:** Smart water meters provide real-time data on water consumption, allowing utility companies and consumers to monitor usage patterns and detect leaks promptly.

**Accuracy:** Automated meter reading eliminates human errors associated with manual readings, ensuring accurate and reliable data collection.

**Efficiency:** Smart meters streamline the meter reading process, reducing the need for manual inspections and saving time and resources for utility companies.

**Cost Savings:** By reducing the need for physical inspections and optimizing water distribution, smart water meters can lead to cost savings for utility providers and, in turn, potentially lower water bills for consumers.

**Leak Detection:** Smart meters can quickly identify and alert both utility companies and consumers to potential leaks, preventing water wastage and minimizing damage to infrastructure.

## CONCLUSION

The implementation of a smart water meter reading project has proven to be a significant advancement in water management and resource conservation. The project aimed to automate the process of water meter reading, providing real-time data and improving accuracy. The adoption of smart technology has brought about several benefits, including operational efficiency, reduced human errors, and increased transparency in water usage tracking.

The deployment of smart water meters has enabled more accurate and timely billing for consumers, leading to improved customer satisfaction. Additionally, the ability to monitor water consumption in real-time allows for early detection of leaks, enabling prompt maintenance and reducing water wastage. The project has also contributed to a more sustainable use of water resources, aligning with global efforts to address water scarcity and promote efficient water management practices.

## FUTURE SCOPE

**Integration with IoT and Smart Cities:** Explore opportunities to integrate smart water meter data into larger IoT networks and smart city initiatives. This could lead to more comprehensive data analysis and improved urban planning based on water consumption patterns.

**Advanced Analytics and Predictive Maintenance:** Develop and implement advanced analytics to predict water usage trends, identify potential issues, and enable predictive maintenance. This proactive approach can further enhance the efficiency of water distribution systems.

**Customer Engagement and Education:** Enhance customer engagement by providing them with personalized insights into their water usage patterns. Develop educational programs to raise awareness about water conservation, encouraging consumers to make informed decisions about their water consumption.

**Remote Monitoring and Control:** Explore possibilities for remote monitoring and control of water meters. This could involve the development of mobile apps or web interfaces that allow consumers to monitor and control their water usage, fostering a sense of responsibility and awareness.

## REFERENCES

1. "Smart Water Management System Using IoT" by K. Vijaya Kumar, K. Ramalingam, and S. Sivakumar (International Journal of Scientific & Engineering Research, 2017), It helps in using IoT technologies to plan, develop, distribute, and manage water resources
2. IoT for Water Management: Article on IoT applications in water management.
3. Smart Water Network Forum: Offers reports, case studies, and resources related to smart water technologies. its non-profit organization that promotes the use of data technologies in water, wastewater, and stormwater networks
4. World Bank - Smart Water: A Key to Sustainable Cities: Provides insights into the role of smart technologies in water management.
5. "Smart Water Metering for Smart Cities: An Overview" by P. Arun and M. Suganthi (International Journal of Engineering Science and Computing, 2016), It helps in automate and help reduce water loss, such as leaks, throughout the entire water distribution network
6. G. M. Kumar, V. V. Manohar, and K. S. Rao, "Design and development of smart water metering system using IoT technology," 2017 International Conference on Intelligent Sustainable Systems (ICISS), Palladam, India, 2017, pp. 358-362. doi: 10.1109/ICISS.2017.8388795.

7. T. K. T. Hlaing, Y. H. Sein, and S. M. Z. Aung, "Smart water metering system using IoT," 2018 International Conference on Intelligent Sustainable Systems (ICISS), Chennai, India, 2018, pp. 827-830. doi: 10.1109/ISS1.2018.8663483.
8. D. Gupta, A. Verma, and V. Aggarwal, "Smart water metering system using IoT," 2019 10th International Conference on Computing, Communication and Networking Technologies (ICCCNT), Kanpur, India, 2019, pp. 1-6. doi: 10.1109/ICCCNT45670.2019.8943922.
9. A. N. Patil and S. S. Kulkarni, "Development of smart water metering system using IoT," 2020 International Conference on Power Electronics, Intelligent Control and Energy Systems (ICPEICES), Delhi, India, 2020, pp. 1909-1914. doi: 10.1109/ICPEICES48637.2020.9073571.
10. K. H. Al-Jawad and A. M. Al-Banna, "Smart water metering system using IoT for sustainable water management," 2021 4th International Conference on Electrical and Electronic Engineering (ICEEE), Sulaymaniyah, Iraq, 2021, pp. 1-5. doi: 10.1109/ICEEE51266.2021.9668339.