

OFF-BOARD ELECTRIC VEHICLE BATTERY CHARGER USING FUZZY WITH PV ARRAY

¹Sankar Reddy Gangavaram Veera,²G Surendra,³Sana Venkata Prathap Reddy

^{1,2}Associate Professor,⁴Assistant Professor

Department Of EEE

Tadipatri Engineering College, Tadipatri, AP

ABSTRACT

During the recent decade, the automobile industry is booming with the evolution of electric vehicle (EV). Battery charging system plays a major role in the development of EVs. Charging of EV battery from the grid increases its load demand. This leads to propose a photovoltaic (PV) array-with controller based off-board EV battery charging system in this study. Irrespective of solar irradiations, the EV battery is to be charged constantly which is achieved by employing a backup battery bank in addition to the PV array. Using the sepic converter and three-phase bidirectional DC-DC converter, the proposed system is capable of charging the EV battery during both sunshine hours and non-sunshine hours. During peak sunshine hours, the backup battery gets charged along with the EV battery and during non-sunshine hours, the backup battery supports the charging of EV battery. The proposed charging system is simulated using Simulink in the MATLAB software and the results are furnished.

1.INTRODUCTION

Ever increasing effects of greenhouse gases from the conventional IC engines lead to environmental concerns. This paved to the booming of pollution free electric vehicles (EVs) in the automobile industry [1-3]. However, EV battery charging from the utility grid increases the load demand on the grid and eventually increases the electricity bills to the EV owners which necessitate the use of alternate energy sources [4, 5]. Due to inexhaustible and pollution free nature of renewable energy sources (RESs), it can be used to charge the EV battery. Thus, RES driven EV can be termed as 'green transportation' [6]. Solar is one of the promising RESs which can be easily tapped to utilise its energy to charge EV battery [7, 8]. Hence, PV array power is used to charge the EV battery in the proposed system with the help of power converter topologies. Lithium ion batteries are widely used in the EV due to its high power density, high efficiency, light weight and compact

size [9, 10]. Also, these batteries have the capacity of fast charging and long lifecycle with low self-discharge rate. They also have low risk of explosion if it is over charged or short circuited. During charging, these batteries require precise voltage control. Hence, various power electronic converters with voltage controller are used for charging EV battery. Due to the intermittent nature of the PV array, there is a need for power converters to charge the EV battery. Among different converters, multiport converters (MPCs) are preferred in the on board chargers of hybrid EVs due to its capability of interfacing power sources and energy storage elements like PV array, ultracapacitors, super capacitors, fuel cells and batteries with the loads in EV like motor, lights, power windows and doors, radios, amplifiers and mobile phone charger. The MPCs have the drawback of increase in weight, cost and maintenance of the EV as all the sources are placed in the EV itself. Also, the complexity of controller implementation increases in these converter-based EV battery charging system [11-13]. Hence, an off-board charger is proposed in this paper in which the EV battery is located inside the vehicle unit and PV array and backup battery bank are located in the charging station or parking station. Various converter topologies for off-board charging system are presented in the literature [14-16].

Among different converter topology, the sepic converter is preferred due to its capability of working in both boost and buck modes. It also has the advantage of the same input and output voltage polarity, low input current ripple and low EMI [17, 18]. However, during low solar irradiation and non-sunshine hours, there is a need for an additional storage battery bank to charge the EV battery. This backup battery bank has to be charged in the forward direction and discharged in a reverse direction depending on the solar irradiation. Hence, a bidirectional converter with power flow in either direction is required [19]. The bidirectional converters are classified into non-isolated and

isolated converters. Transformer in the isolated converters provides isolation which increases the price, weight and size of the converter. The main concerns of EV are weight and size and hence, non-isolated bidirectional converters are best suited for this application [20–22]. Among various non-isolated bidirectional converter topologies, bidirectional interleaved DC–DC converter (BIDC) is preferred due to its advantages like improved efficiency in discontinuous conduction mode and minimal inductance value, reduced ripple current due to multiphase interleaving technique. Snubber capacitor across the switches reduces the turnoff losses and the inductor current parasitic ringing effect is also reduced by employing zero voltage resonant soft switching technique. These are the added advantages of this bidirectional converter [23–25]. The system in [25] is an off-board EV battery charging system which charges the EV battery from PV array power through bidirectional DC–DC converter in stand-still condition and EV battery gets discharged to drive the dc load in the EV during the running condition. It has the drawback of charging EV battery only during sunshine hours. To overcome this disadvantage and to charge the EV battery without any interruption, the proposed charger is developed using PV array integrated with sepic converter, bidirectional DC–DC converter and backup battery bank for charging the battery of an EV.

II. LITERATURE SURVEY

Santosh, T.K., Govindaraju, C.: ‘Dual input dual output power converter with one-step-ahead control for hybrid electric vehicle applications. The rapid conversion of automotive accessory loads to the electrical domain demands a power converter to interface between the on-board source and storage units with the accessories. This study proposes a simplified structure of dual input dual output (DIDO) with single-stage power conversion for hybrid electric vehicle accessory applications. The topology is synthesised using pulsating source cells. The generic switch model-based DIDO is realised with power switches based on switch realisation technique. Steady-state and equivalent circuit models describing the converter structure are presented. Numerical simulations were performed with the state-space averaged mathematical model. A one-step-ahead controller is used for inductor current control in conjunction with a mode selection logic to utilise its operating modes based on the availability of the

sources and its protection. The performance of the proposed converter and its associated control scheme under steady-state, transient conditions are corroborated by simulation and experimental results.

Shukla, A., Verma, K., Kumar, R.: ‘Voltage-dependent modelling of fast charging electric vehicle load considering battery characteristics’: Electric vehicle (EV) integration into the power grids is increasing rapidly. To analyse the effect of charging of EVs on the distribution system, most of the literature considered EV load as constant power load (CPL) which do not represent the exact behaviour of these uncertain loads. An accurate EV load modelling is developed by determining the relationship between power consumption by EV, grid voltage and state of charges of fast charging EV load. The derived relationship is validated by simulating a realistic fast charging system to obtain a battery charging behaviour characteristics and is curve fitted on standard exponential load model. Further the impact of stochastic 24-h load profile of fast charging EVs considering the exponential load model is investigated on IEEE 123 bus distribution system and is compared with the constant impedance-constant current-constant power (ZIP) load model and CPL model. The stochastic 24-h load is developed using queuing analysis-based method. The results show that the exponential load model is the better representation of fast charging EV load and 10.19% of the reduction in annual energy demand and 11.19% of the reduction in annual energy loss is observed for exponential load model compared to the existing CPL model.

Wirasingha, S.G., Emadi, A.: ‘Pihef: plug-in hybrid electric factor’, The potential of plug-in hybrid electric vehicles (PHEVs) to operate in electric and hybrid modes and their ability to supplement the energy storage off the grid have made them a front-runner in alternative fuel vehicle development. However, there is currently no widely accepted standard classification that provides an accurate comparison of PHEVs. This paper presents a novel classification for PHEVs: “Pihef: Plug-In Hybrid Electric Factor.” Pihef is the average ratio of the energy provided by the grid to the sum of the energy provided by the grid and fuel. The viability of Pihef is demonstrated via comprehensive simulations and a sensitivity analysis. In addition, the relationship between Pihef

and emissions, efficiency, hybridization, and electric range is developed.

Kirthiga, S., Jothi Swaroopan, N.M.: 'Highly reliable inverter topology with anovel soft computing technique to eliminate leakage current in grid-connected transformerless photovoltaic systems'

Grid-connected transformerless photovoltaic inverters are widely accepted in the renewable energy market, owing to their high power density, low cost, and high efficiency. However, the leakage current is the main issue in these inverters, which is to be investigated carefully. In this study, leakage current analysis of both transformer and transformerless bridge inverter topologies are widely investigated. Based on that, a new topology and modulation technique is proposed to eliminate the leakage current in the system. The mechanism of a creating high-impedance path between the photovoltaic module and the system, by properly isolating them in the freewheeling state and maintaining a constant common mode voltage in all the switching states, is elaborately discussed in this paper. The experimental results are finally presented to validate the proposed topology with respect to other conventional topologies.

Badawy, M.O., Sozer, Y: 'Power flow management of a grid tied PV-battery system for electric vehicles charging' The prospective spread of Electric vehicles (EV) and plug-in hybrid electric vehicles arises the need for fast charging rates. High required charging rates lead to high power demands, which may not be supported by the grid. In this paper, an optimal power flow technique of a PV-battery powered fast EV charging station is presented to minimize the operation cost. The objective is to help the penetration of PV-battery systems into the grid to support the growing need for fast charging of EVs. An optimization problem is formulated along with the required constraints and the operating cost function is chosen as a combination of electricity grid prices and the battery degradation cost. In the first stage of the proposed optimization procedure, an offline particle swarm optimization (PSO) is performed as a prediction layer. In the second stage, dynamic programming (DP) is performed as an online reactive management layer. Forecasted system data is utilized in both stages to find the optimal solution for the power management. In the reactive management layer, the outputs of the PSO

are used to limit the available state trajectories used in the DP and, accordingly, improve the system computation time and efficiency. Online error compensation is implemented into the DP and fed back to the prediction layer for necessary prediction adjustments. Simulation and experimental results are successfully implemented to validate the effectiveness of the proposed management system.

Van Der Meer, D., Chandra Mouli, G.R., Morales-Espana Mouli, G., et al.: 'Energy management system with PV power forecast to optimally charge EVs at the Workplace This paper presents the design of an energy management system (EMS) capable of forecasting photovoltaic (PV) power production and optimizing power flows between PV system, grid, and battery electric vehicles (BEVs) at the workplace. The aim is to minimize charging cost while reducing energy demand from the grid by increasing PV self-consumption and consequently increasing sustainability of the BEV fleet. The developed EMS consists of two components: An autoregressive integrated moving average model to predict PV power production and a mixed-integer linear programming framework that optimally allocates power to minimize charging cost. The results show that the developed EMS is able to reduce charging cost significantly, while increasing PV self-consumption and reducing energy consumption from the grid. Furthermore, during a case study analogous to one repeatedly considered in the literature, i.e., dynamic purchase tariff and dynamic feed-in tariff, the EMS reduces charging cost by 118.44% and 427.45% in case of one and two charging points, respectively, when compared to an uncontrolled charging policy.

Xavier, L.S., Cupertino, A.F., Pereira, H.A.: 'Ancillary services provided by photovoltaic inverters: single and three phase control strategies : Grid connected photovoltaic (PV) have been inserted in the power systems mainly at low and medium voltage. PV inverters are power electronic based converters with fast response in the range of milliseconds. Besides, due to solar irradiance variation, these converters have excess capacity that can be used to provide ancillary services to the main grid. Traditionally, ancillary services such as reactive power injection and frequency support are provided by hydro and thermal generation. This work is focused on the analysis of how PV inverters can perform ancillary services and support

the grid. Control strategies for reactive power injection and harmonic current compensation are explored. Furthermore, the inverter current saturation plays an important role, once high currents can damage the inverter or reduce its lifetime. Case studies for single and three-phase PV inverters are presented. It is observed that the ancillary service priority must be defined in order to guarantee PV inverter operation under nominal conditions.

III. PHOTOVOLTAIC MODULE:

Modelling is the basis for computer simulation of a real system. It is usually based on a theoretical analysis of the various physical processes occurring in the system and of all factors influencing these processes. The most common model used to predict energy production in photovoltaic cell modelling is the single diode circuit model that represents the electrical behaviour of the pn-junction is given in fig 1 Figure shows how photovoltaic system works. The ideal photovoltaic module consists of a single diode.

A solar cell is the building block of a solar panel. A photovoltaic module is formed by connecting many solar cells in series and parallel. Considering only a single solar cell; it can be modelled by utilizing a current source, a diode and two resistors. This model is known as a single diode model of solar cell

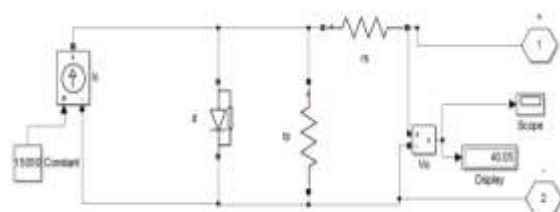

Figure 1: Single diode model of a solar cell

3.1 Introduction to fuzzy

In recent years, the number and variety of applications of fuzzy logic have increased significantly. The applications range from consumer products such as cameras, camcorders, washing machines, and microwave ovens to industrial process control, medical instrumentation, decision support systems, and portfolio selection. To understand why use of fuzzy logic has grown, you must first understand what is meant by fuzzy logic.

Fuzzy logic has two different meanings. In a narrow sense, fuzzy logic is a logical system, which is an extension of multivalve logic. However, in a wider sense fuzzy logic (FL) is almost synonymous

with the theory of fuzzy sets, a theory which relates to classes of objects with unsharp boundaries in which membership is a matter of degree. In this perspective, fuzzy logic in its narrow sense is a branch of FL. Even in its more narrow definition, fuzzy logic differs both in concept and substance from traditional multivalve logical systems.

The fuzzy logic toolbox is highly impressive in all respects. It makes fuzzy logic an effective tool for the conception and design of intelligent systems. The fuzzy logic toolbox is easy to master and convenient to use. And last, but not least important, it provides a reader friendly and up to date introduction to methodology of fuzzy logic and its wide ranging applications.

What is fuzzy logic?

Fuzzy logic is all about the relative importance of precision is how important is it to be exactly right when a rough answer will do?

You can use Fuzzy Logic Toolbox software with MATLAB technical computing software as a tool for solving problems with fuzzy logic. Fuzzy logic is a fascinating area of research because it does a good job of trading off between significance and precision something that humans have been managing for a very long time. In this sense, fuzzy logic is both old and new because, although the modern and methodical science of fuzzy logic is still young, the concept of fuzzy logic relies on age old skills of human reasoning.

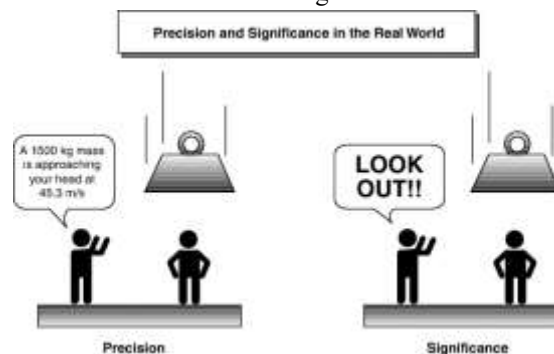

IV. OPERATION OF THE PROPOSED SYSTEM

The proposed PV-EV battery charger consists of a PV array, a sepic converter, a half-bridge BIDC, an EV battery, a backup battery bank and a controller as shown in Fig. 1. The controller is used to generate the gate pulses to the sepic converter for obtaining the constant output voltage at the dc link. The gate pulses to the switches of BIDC are also generated to operate BIDC in boost mode to charge the backup battery from PV array and in buck mode to charge EV battery from the

backup battery. Also, the controller generates the gate pulses to the auxiliary switches Sa, Sb and Sc. During high solar irradiation, all the auxiliary switches are ON to interface dc link with PV array through the sepic converter, dc link with the backup battery through BIDC and dc link with EV battery. When solar irradiation is low, switch Sa is turned OFF isolating the PV array and sepic converter from the dc link. Whereas the switch Sc is turned OFF to disconnect BIDC and backup battery from the dc link, when the solar power is insufficient to charge backup battery. The proposed system operates in three modes viz., mode 1, mode 2 and mode 3 as explained in this section.

Mode 1

During peak sunshine hours, when the generated PV array power is higher, all the auxiliary switches are ON to charge both EV battery and backup battery simultaneously from PV array through sepic converter and BIDC, respectively. In this mode, BIDC operates in forward direction boosting the dc link voltage to charge backup battery.

Mode 2

Low solar irradiation conditions and non-sunshine hours, PV array power is insufficient to charge EV battery. Hence, the PV array is disconnected from the dc link by turning OFF the switch Sa and switches Sb & Sc are ON connecting EV battery to the backup battery through BIDC. In this mode, BIDC operates in reverse direction stepping down the backup battery voltage to charge EV battery.

Mode 3

When PV array power generated is sufficient to charge only EV battery, switches Sa and Sb are ON and switch Sc is OFF to disconnect the BIDC and backup battery bank from the dc link.

4.1 DESIGN OF THE CONVERTERS USED IN THE PROPOSED CHARGER

Sepic converter

In the proposed charging system, the sepic converter provides the constant output voltage irrespective of the PV array voltage by adjusting its duty ratio using the PI controller. The sepic converter consists of one IGBT switch, one diode, two inductors and two capacitors as shown in Fig. 2. The major advantages of the sepic converter are:

- (i) it can operate in both boost and buck modes depending on the duty ratio;
 - (ii) it provides the output voltage with the same polarity as input voltage unlike buck–boost and cuk converters [16].
- The voltage gain of the sepic converter is provided by the following equation:

$$\frac{V_{dc}}{V_{PV}} = \frac{D}{1-D} \dots\dots\dots (1)$$

where Vdc is the dc link voltage, VPV is the PV array voltage and D is the duty ratio of the sepic converter. The values of inductors and capacitors of the sepic converter are chosen as per (2)–(4) [17]:

$$L_a = L_b = \frac{V_{PVmin}D_{max}}{2\Delta i_{PV}f_{sw}} \dots\dots\dots (2)$$

$$C_1 = \frac{I_{dc}D_{max}}{\Delta V_{C1}f_{sw}} \dots\dots\dots (3)$$

$$C_2 = \frac{I_{dc}D_{max}}{\Delta V_{dc}f_{sw}} \dots\dots\dots (4)$$

Where VPVmin is the minimum PV array voltage, ΔiPV is the input current ripple, fsw is the switching frequency, Idc is the dc link

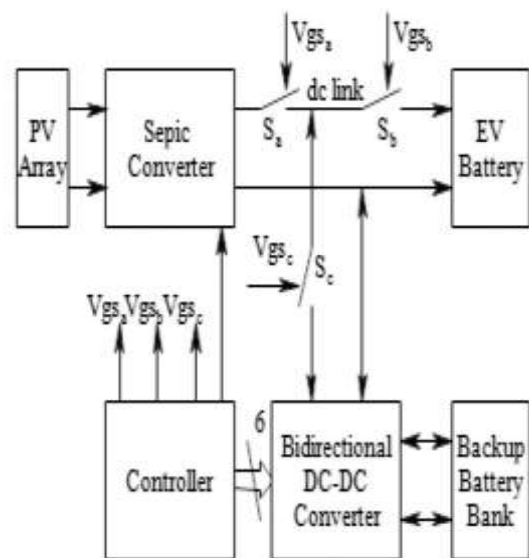

Fig. 2 Block diagram of the EV battery charger

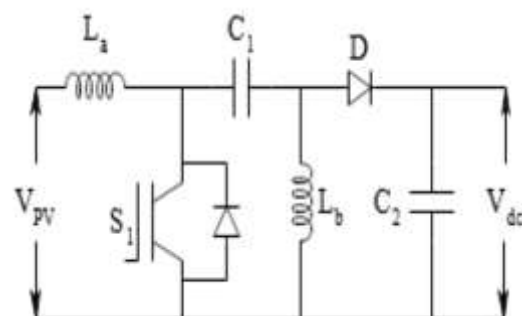

Fig. 3 Schematic diagram of sepic converter

current, ΔV_{C1} is the capacitor, $C1$ voltage ripple, ΔV_{dc} is the output voltage ripple, and D_{max} is the maximum duty ratio calculated as follows:

$$D_{max} = \frac{V_{dc} + V_D}{V_{PVmin} + V_{dc} + V_D} \dots\dots (5)$$

Where V_D is the diode voltage drop.

4.2 BIDIRECTIONAL INTERLEAVED DC-DC CONVERTER

Fig. 3 shows the schematic diagram of the B IDC employed in the proposed charging system. Backup battery bank is located on the high voltage side while the dc link is on the low voltage side of the converter. This converter operates in boost mode in forward direction and in buck mode in reverse direction. In boost mode, switches $SL1$, $SL2$ and $SL3$ are the active switches whereas, in buck mode, the active switches are $SU1$, $SU2$ and $SU3$. There is an anti parallel diode and parallel snubber capacitor to all the switches employed in this converter. In boost mode, the inductors $L1$, $L2$ and $L3$ act as boost inductors whereas they act as a low-pass filter in buck mode. The capacitors, C_L and C_H are the smoothing energy buffer elements of this converter. Interleaved inductor currents minimize the ripples in the current. The modes of operation of the converter are analysed by considering the operation of a single leg converter in [20]. The voltage conversion ratio of B IDC in boost and buck modes are given by (6) and (7), respectively.

$$\frac{V_{BackupBatt}}{V_{dc}} = \frac{1}{1 - D_{Boost}} \dots\dots\dots (6)$$

$$\frac{V_{dc}}{V_{BackupBatt}} = D_{Buck} \dots\dots\dots (7)$$

Where $V_{Backup Battery}$ is the backup battery voltage and D_{Boost} is the duty ratio of B IDC in boost mode and D_{Buck} is the buck mode duty ratio. The values of inductors are considered less than the critical inductance values in both boost and buck modes to operate the converter in discontinuous conduction mode to improve efficiency

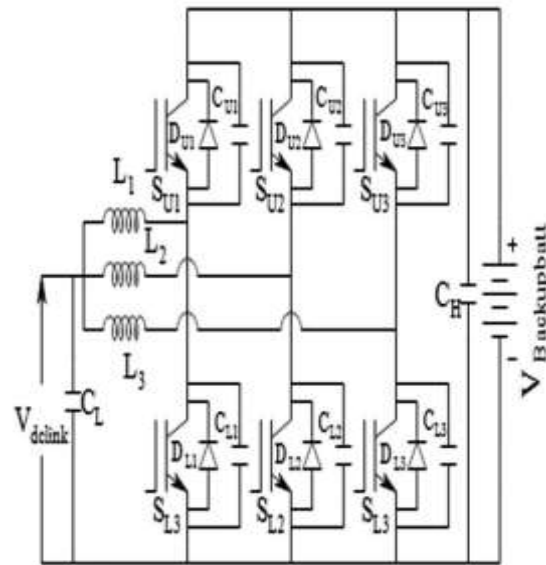

Fig.4 Schematic diagram of half-bridge B IDC [20]. the critical inductance value is calculated in boost and buck modes using (8) and (9), respectively.

$$L_{critic} = \frac{3V_{BackupBatt}^2 D_{Boost}(1 - D_{Boost})^2}{2P f_s} \dots\dots (8)$$

$$L_{critic} = \frac{3V_{dc}^2(1 - D_{Buck})}{2P f_s} \dots\dots\dots (9)$$

Where P is the Backup battery power. The values of the capacitors on the low and high voltage side of B IDC are considered based on the following equations:

$$C_H = \frac{D_{Boost}P}{2f_s V_{BackupBatt}^2} \dots\dots\dots(10)$$

$$C_L = \frac{V_{BackupBatt} D_{Buck}(1 - D_{Buck})}{8f_s^2 L \Delta V_{dc}} \dots\dots\dots(11)$$

4.3 DESIGN OF CONTROLLERS

Controller of the proposed charger generates gate pulses to the switches present in the sepic converter, B IDC and also to the three auxiliary switches. The algorithm to turn ON and turn OFF the auxiliary switches is shown in Fig. 4. Controller senses the PV array voltage and current, and computes the PV array power. If the PV array power is greater than EV battery rated power, P_R , then the controller generates the gate pulses to turn

ON all the auxiliary switches to charge both EV battery and backup battery bank simultaneously from the PV array. If the PV array power is lesser than EV battery rated power but higher than the minimum required power, P_M , the switch, S_c is turned OFF disconnecting the backup battery from the charging system and switches, S_a and S_b are turned ON to charge the EV battery alone from the PV array. If the PV array power is lesser than the minimum required power, P_M , then the switch, S_a is turned OFF to isolate the PV array and sepic converter from the charging system. The switches, S_b and S_c are turned ON enabling the backup battery to charge EV battery. The PI voltage controller is used in the proposed charging system to generate gate pulses to the MOSFET in the sepic converter to maintain a constant voltage at the dc link irrespective of variations in the PV array voltage. BIDD comprises of three legs with two switches in each leg. Gate pulses have to be provided to the two switches in the same leg with the phase shift of 180° from each other. The controller in the proposed system generates six gate pulses to the BIDD depending on the PV array power. If PV array power exceeds P_R , gate pulses are generated to the switches of BIDD to operate it in boost mode, stepping up the dc link voltage to charge the backup battery bank. In this mode, the gate pulses are generated to the switches of leg 1 with 0° phase and to the leg 2 switches with 120° phase shift from that of leg 1 switches and to the leg 3 switches with 240° phase shift from that of leg 1 switches. If the PV array power is less than P_M , the gate pulses are generated accordingly to operate BIDD in

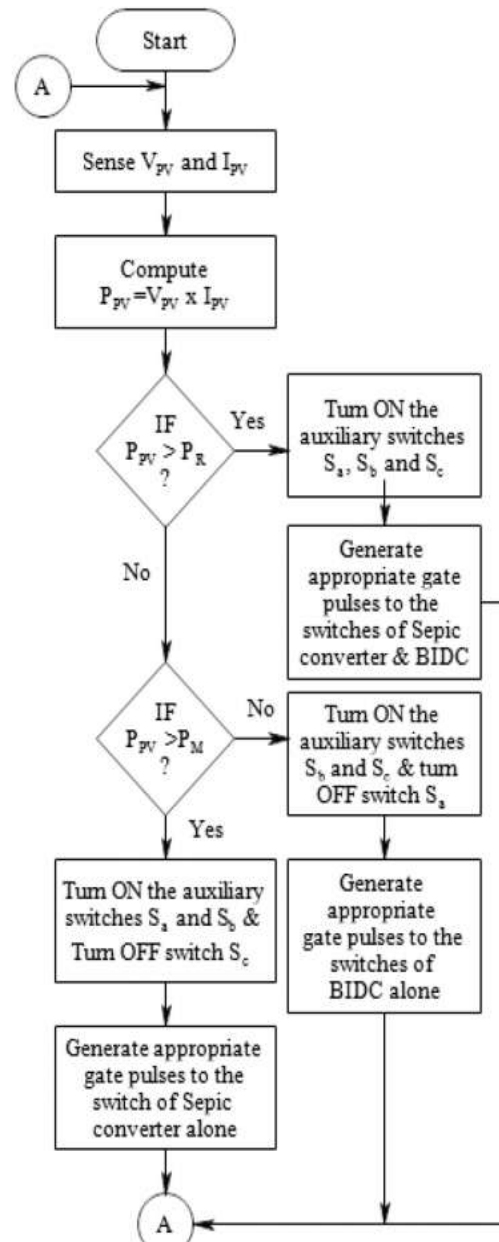

Fig. 5: Flowchart of gate pulses generation for the auxiliary switches

Buck mode, producing a step down voltage at the dc link sufficient to charge the EV battery by the backup battery. In this mode, the gate pulses are fed to the leg 3 switches with 0° phase and gate pulses to the leg 2 and leg 1 switches are 120° and 240° phase shifted with respect to that of leg 3 switches, respectively.

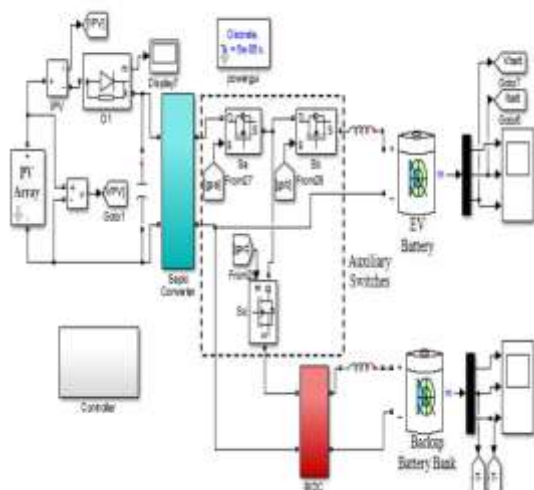

Fig.6 Simulation model of the proposed charger

4.4. MATHEMATICAL MODELLING OF PROPOSED SYSTEM

Mathematical model of the proposed system is obtained by combining the state-space average model of Sepic converter and Bidirectional DC–DC converter. It is derived by considering the ON and OFF switching period of the converters [26, 27]. The state space matrices of the sepic converter, state matrix ‘A’, input matrix ‘B’, output matrix ‘C’, feed forward matrix ‘D’ are found to be

$$A = \begin{bmatrix} 0 & 0 & \frac{-(1-D_s)}{L_a} & \frac{-(1-D_s)}{L_a} \\ 0 & 0 & \frac{D_s}{L_b} & \frac{-(1-D_s)}{L_b} \\ \frac{(1-D_s)}{C_1} & \frac{-D_s}{C_1} & 0 & 0 \\ \frac{(1-D_s)}{C_2} & \frac{(1-D_s)}{C_2} & 0 & \frac{-1}{C_2 R_{eq}} \end{bmatrix} \dots\dots(12)$$

$$B = \begin{bmatrix} \frac{1}{L_a} \\ 0 \\ 0 \\ 0 \end{bmatrix} \dots\dots (13)$$

$$C = [0 \ 0 \ 0 \ 1] \dots\dots (14)$$

$$D = [0] \dots\dots (15)$$

Where Req is equivalent impedance at the dc link and Ds is the duty ratio of Sepic converter. Similarly, the state-space matrices of the BIDC, state matrix ‘A1’, input matrix ‘B1’, output matrix ‘C1’, feed forward matrix ‘D1’ are found to be

$$A_1 = \begin{bmatrix} \frac{-(R_{lp} + R_{dson})}{L} & 0 & \frac{-(1 - D_{BIDC})}{L} \\ \frac{-1 + 2D_{BIDC}}{C_L} & 0 & 0 \\ \frac{(1 - D_{BIDC})}{C_H} & 0 & \frac{-1}{C_H R_{eq1}} \end{bmatrix} \dots\dots$$

(16)

$$B_1 = \begin{bmatrix} \frac{1}{L} \\ 0 \\ 0 \end{bmatrix} \dots\dots (17)$$

$$C_1 = [0 \ 0 \ 1] \dots\dots (18)$$

$$D_1 = [0] \dots\dots (19)$$

where L = (L1/3), Rlp = (RL1/3),

Req1 is equivalent impedance across capacitor CH, Rdsn the MOSFET turn on resistance, RL1 is the parasitic resistance of inductor, L1 and DBIDC is the duty ratio of BIDC. Transfer functions of the converters are obtained from the above state-space models and they are combined to produce the overall transfer function of the proposed system. Frequency response of the proposed system exhibits the positive gain margin and phase margin which in turn indicates that the proposed system is stable. Simulation studies of the proposed charger are carried out and the results are furnished in the following section.

V.SIMULATION RESULTS

Simulink in the MATLAB software is used for the simulation studies of the proposed system. PV array is modelled using its classical equation [28, 29]. The Sepic and BIDC converter is modeled using power MOSFETs, inductors and capacitors available in Sim Power Systems Block set in simulink library. Controller is developed using PWM generator, pulse generator, logic gates, comparator, and multiplier and PI controller available in the Simulink library. PV array model is integrated with the

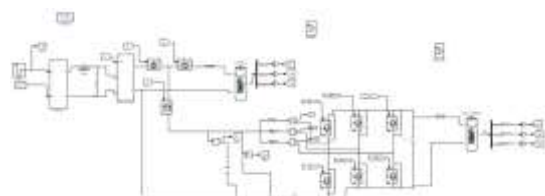

Fig.7 Simulation model of (a) Sepic converter, (b) BIDC with Fuzzy

Developed sepic converter and BIDC along with the battery models available in Simulink library for developing the proposed charging

Arts and Humanities Archives

system as shown in Fig. 5. The developed simulation model of sepic converter and BIDD shown as subsystems in Fig. 5 are depicted in Figs. 6a and b, respectively. The dynamic response of the system was investigated using the developed simulation model for PV array irradiation of 850, 100 and 500 W/m² in mode 1, mode 2 and mode 3, respectively. The simulation results showing PV array voltage and current waveforms along with the gate pulses to the auxiliary switches are depicted in Fig. 7. Irradiation waveforms are shown in the scale of 1 for 1000 W/m² in Fig. 7. Thus, both EV battery and backup battery gets charged simultaneously in this mode. Whereas at low irradiation of 100 W/m², the gate pulses of auxiliary switches, V_{gsb} and V_{gsc} are high and gate pulse, V_{gsa} is low as PV array power is insufficient for charging EV battery. Thus, the backup battery bank discharges through BIDD to charge EV battery in this mode. During irradiation of 500 W/m², the auxiliary switches S_a and S_b are ON and switch S_c is OFF disconnecting backup battery from the system. Since PV array power is sufficient only for charging EV battery, backup battery is isolated and not charged in this mode. Fig. 7 shows that the gate pulses to the switch S_b is always high as the EV battery is constantly charged in all the three modes. If the EV battery is fully charged, EV battery is isolated from the

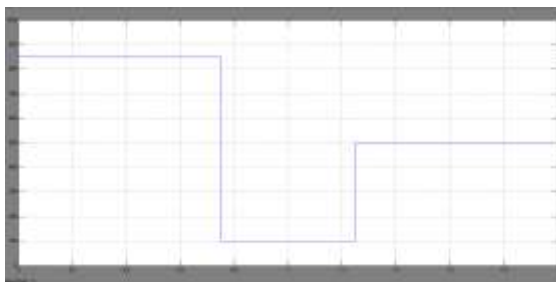

Fig: Irradiance

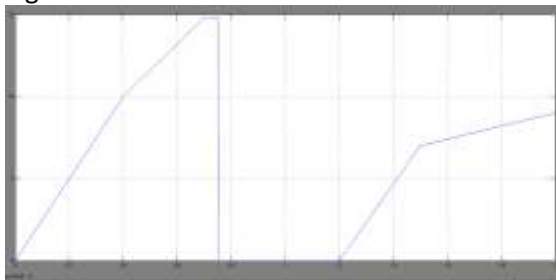

Fig: I_{pv}

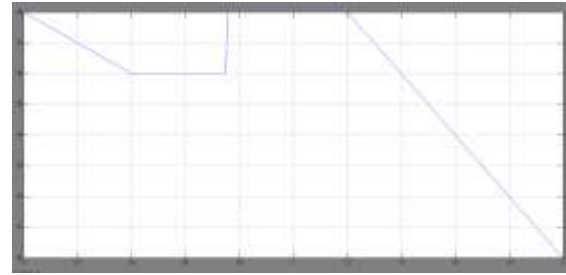

Fig: V_{pv}

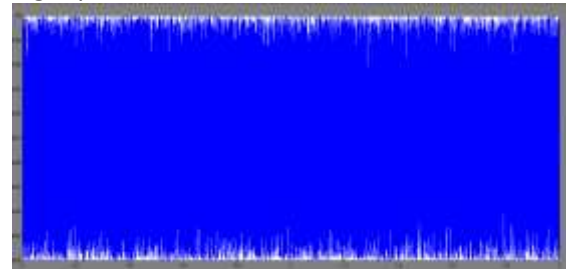

Fig: V_{dc}

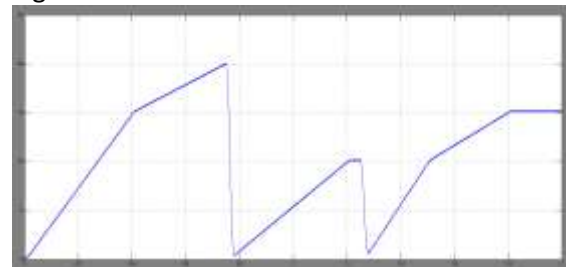

Fig: I_{dc}

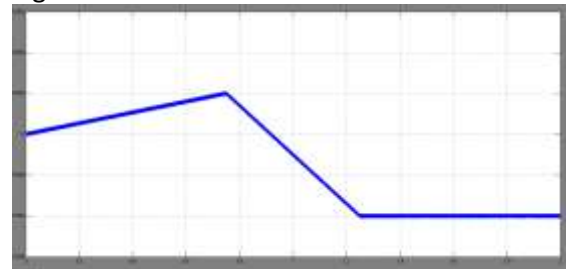

Fig: Battery-Soc

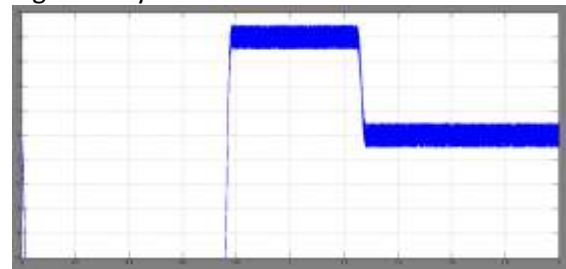

Fig: I_{bat-b}

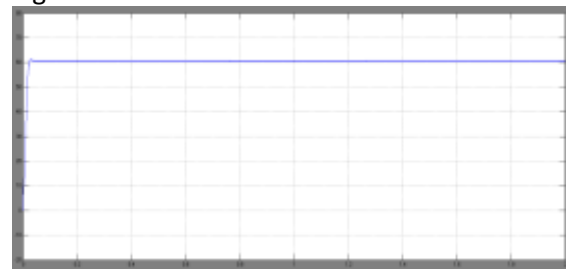

Fig: V_{bat-b}

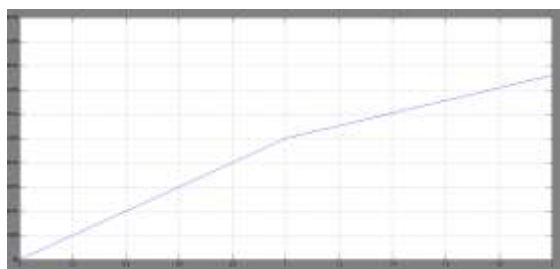

Fig: Soc-battery-a

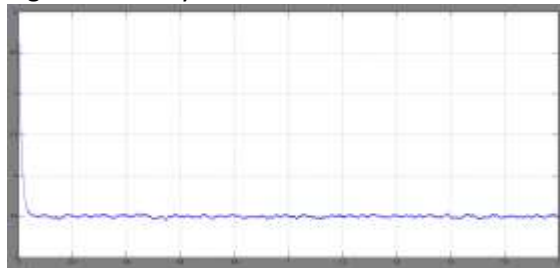

Fig:ibat-a

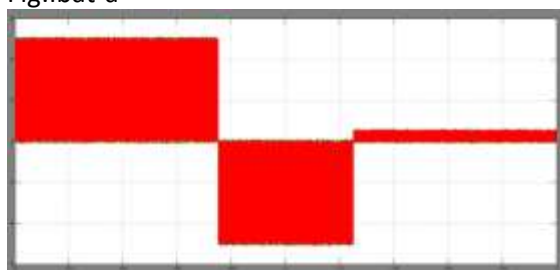

Fig:lla,ilb, ilc

V.CONCLUSION

In this project, an off-board EV battery charging system fed from PV array with is proposed. This project discusses the flexibility of the system to charge the EV battery constantly irrespective of the irradiation conditions. The system is designed and simulated in Simulink environment of the MATLAB software. The with PV simulation tested in laboratory for the three modes of operation of the proposed charging system separately and the results are furnished. Investigation is carried out in RCP methodology and the dynamic response of the system is furnished both in simulation investigation.

REFERENCES

- [1] Santhosh, T.K., Govindaraju, C.: 'Dual input dual output power converter with one-step-ahead control for hybrid electric vehicle applications', *IET Electr. Syst. Transp.*, 2017, 7, (3), pp. 190–200
- [2] Shukla, A., Verma, K., Kumar, R.: 'Voltage-dependent modelling of fast charging electric vehicle load considering battery characteristics', *IET Electr. Syst. Transp.*, 2018, 8, (4), pp. 221–230

- [3] Wirasingha, S.G., Emadi, A.: 'Pihef: plug-in hybrid electric factor', *IEEE Trans. Veh. Technol.*, 2011, 60, pp. 1279–1284
- [4] Kirthiga, S., Jothi Swaroopan, N.M.: 'Highly reliable inverter topology with a novel soft computing technique to eliminate leakage current in grid-connected transformerless photovoltaic systems', *Comput. Electr. Eng.*, 2018, 68, pp. 192–203
- [5] Badawy, M.O., Sozer, Y.: 'Power flow management of a grid tied PV-battery system for electric vehicles charging', *IEEE Trans. Ind. Appl.*, 2017, 53, pp. 1347–1357
- [6] Van Der Meer, D., Chandra Mouli, G.R., Morales-Espana Mouli, G., et al.: 'Energy management system with PV power forecast to optimally charge EVs at the workplace', *IEEE Trans. Ind. Inf.*, 2018, 14, pp. 311–320
- [7] Xavier, L.S., Cupertino, A.F., Pereira, H.A.: 'Ancillary services provided by photovoltaic inverters: single and three phase control strategies', *Comput. Electr. Eng.*, 2018, 70, pp. 102–121
- [8] Krithiga, S., Ammasai Gounden, N.: 'Investigations of an improved PV system topology using multilevel boost converter and line commutated inverter with solutions to grid issues', *Simul. Model. Pract. Theory*, 2014, 42, pp. 147–159
- [9] Sujitha, N., Krithiga, S.: 'RES based EV battery charging system: a review', *Renew. Sustain. Energy Rev.*, 2017, 75, pp. 978–988
- [10] Farzin, H., Fotuhi-Firuzabad, M., Moeini-Aghaie, M.: 'A practical scheme to involve degradation cost of lithium-ion batteries in vehicle-to-grid applications', *IEEE Trans. Sustain. Energy*, 2016, 7, pp. 1730–1738
- [11] Zubair, R., Ibrahim, A., Subhas, M.: 'Multiinput DC–DC converters in renewable energy applications – an overview', *Renew. Sustain. Energy Rev.*, 2015, 41, pp. 521–539
- [12] Duong, T., Sajib, C., Yuanfeng, L., et al.: 'Optimized multiport dc/dc converter for vehicle drive trains: topology and design optimization', *Appl Sci.*, 2018, 1351, pp. 1–17
- [13] Santhosh, T.K., Natarajan, K., Govindaraju, C.: 'Synthesis and implementation of a multi-port dc/dc converter for hybrid electric vehicles', *J. Power Electron.*, 2015, 15, (5), pp. 1178–1189
- [14] Hongfei, W., Peng, X., Haibing, H., et al.: 'Multiport converters based on integration of full-bridge and bidirectional dc–dc topologies for renewable generation systems', *IEEE Trans. Ind. Electron.*, 2014, 61, pp. 856–869

Arts and Humanities Archives

[15] Shi, C., Khaligh, A.: 'A two-stage three-phase integrated charger for electric vehicles with dual cascaded control strategy', IEEE J. Emerging Sel. Topics Power Electron., 2018, 6, (2), pp. 898–909.