

WEATHER MONITORING SYSTEM USING IOT

Mr. P. APPALA RAJU¹, POLISETTI VIJAY SUBHASH², NETALA RAJA PRADEEP³

¹Assistant Professor, Dept. of ECE, PRAGATI ENGINEERING COLLEGE

^{2,3}UG Students, Dept. of ECE, PRAGATI ENGINEERING COLLEGE

ABSTRACT

Weather monitoring is critical in many aspects. Weather has a direct influence on the agriculture industry, food manufacturing, and many other industries. The condition of the environment, whether hot or cold, humid or dry, calm or turbulent, clear or shady is referred to as the atmosphere. Most temperature anomalies occur in the lower atmosphere, much below the stratosphere. Climate, in general, refers to regular temperature and precipitation movement, whereas atmosphere refers to longer timeframes for normal weather conditions. When the term "climate" is used without capacity, it is intended to denote the Earth's climate. It is physically impossible to track atmospheric conditions. The method suggested in this research is a modern approach used for evaluating climate conditions at a specific location and making data visible throughout a network range. The technology underlying this is the Internet of Things (IoT), which is a cutting-edge and cost-effective method used for connecting things to the internet and linking the infinite of things in a network. Things like electrical gadgets, sensors, and vehicle electronic equipment could be found here. The system uses sensors to monitor and adjust environmental parameters such as temperature, relative humidity, barometric pressure, and rain level, and then sends the information to a web page, where it is plotted. Data from the deployed system can be accessed through the internet by using a smartphone, laptop, computer, or tablet. Overall, the proposed system has produced good results; the predicted outcomes can be accomplished with a high degree of accuracy, while adhering to the system's design with the aim of becoming low-cost and user-friendly.

INTRODUCTION

Here we introduce a smart weather reporting system over the Internet. Our introduced system allows for weather parameter reporting over the Internet. It allows the people to directly check the weather states online without the need of a weather forecasting agency. System uses temperature, humidity as well as rain with humidity sensor to monitor weather and provide live reporting of the weather statistics. The system constantly monitors temperature using

temperature sensor, humidity using humidity sensor and also for rain. Weather monitoring system deals with detecting and gathering various weather parameters at different locations which can be analysed or used for weather forecasting. The aim of this system is achieved by technologies such as Internet of Things (IOT) and Cloud. The idea of internet of things is to connect a device to the internet and to other required connected devices. Using Internet the information from the IOT device can easily be transferred to the cloud and then from the cloud to the end user. Weather Monitoring is an essential practical implementation of the concept of Internet of Things, it involves sensing and recording various weather parameters and using them for alerts, sending notifications, adjusting appliances accordingly and also for long term analysis. Also we will try to identify and display trends in parameters using graphical representation. The devices used for this purpose are used to collect, organize and display information. It is expected that the internet of things is going to transform the world by monitoring and controlling the phenomenon of environment by using sensors/devices which are able to capture, process and transmit weather parameters. Cloud is availability of computer system resources like data storage, computing power without direct active management of user. The data captured is transmitted to the cloud so that the data could be further displayed.

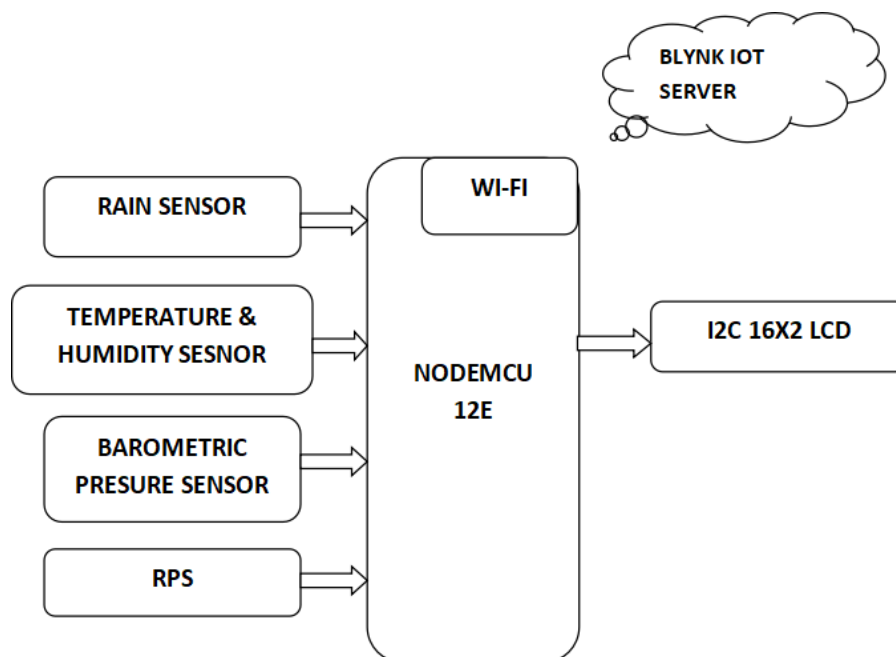

Figure.1 Block Diagram

LITERATURE SURVEY

Define Keywords and Search Queries:

Start by defining keywords related to your topic, such as "IoT weather monitoring," "Internet of Things in meteorology," "smart weather sensors," etc.

Use these keywords to search in academic databases like IEEE Xplore, Google Scholar, ScienceDirect, and relevant IoT and meteorology journals.

Review Academic Papers:

Look for academic papers published in journals and conferences related to IoT, meteorology, environmental monitoring, and sensor networks.

Focus on papers that discuss the design, implementation, deployment, and evaluation of IoT-based weather monitoring systems.

Pay attention to research on sensor technologies, data communication protocols, data analysis techniques, and applications in weather forecasting and climate research.

Explore Patents:

Search for patents related to IoT-based weather monitoring systems. Patent databases like Google Patents or the United States Patent and Trademark Office (USPTO) can be valuable sources of innovative technologies and approaches.

Look for patents related to IoT sensors, data processing algorithms, communication protocols, and integration with weather forecasting systems.

Check Technical Reports and Theses:

Technical reports and theses can provide detailed insights into specific research projects and case studies related to IoT weather monitoring.

Search university repositories and institutional databases for theses and technical reports on IoT applications in meteorology and environmental monitoring.

Look for Review Articles and Book Chapters:

Review articles and book chapters can provide comprehensive summaries of existing research in IoT-based weather monitoring.

Look for literature reviews and survey papers that summarize the state-of-the-art technologies, challenges, and future directions in this field.

Search for Industry Publications and Whitepapers:

Industry publications, company websites, and whitepapers may contain case studies, best practices, and real-world implementations of IoT-based weather monitoring systems.

Look for reports from IoT solution providers, weather technology companies, and research organizations working on environmental monitoring projects.

Consider Standards and Protocols:

Explore IoT standards and communication protocols relevant to weather monitoring applications. Standards bodies like the International Organization for Standardization (ISO) and the Institute of Electrical and Electronics Engineers (IEEE) may have published standards related to IoT sensor networks and data exchange in meteorology.

Evaluate and Summarize Findings:

Evaluate each source based on its relevance, credibility, and contribution to your research.

Summarize the key findings, methodologies, technologies, and challenges identified in the literature. Identify common trends, emerging technologies, gaps, and areas for future research in IoT-based weather monitoring.

PROPOSED SYSTEM

The system consists of components such as Arduino UNO board which is a microcontroller board consisting of 14 digital pins, a USB connection and everything used to support microcontroller; DHT11 is Temperature and humidity sensor which is used for detecting these mentioned parameters; WIFI module is used to convert the data collected from the sensors and then send it to the web server. So, in this way weather conditions of any location can be monitored from any remote location in the world. The system constantly transmits this data to the micro controller which now processes this data and keeps on transmitting it to the online web server over a wifi connection. This data is live updated to be viewed on the online server system. Also system allows user to set alerts for particular instances. In today's world many pollution monitoring systems are designed by different environmental parameters. Existing system model is presented IOT based Weather monitoring and reporting system where you can collect, process, analyze, and present your measured data on web server. Wireless sensor network management model consists of end device, router, gateway node and management monitoring center. End device is responsible for collecting wireless sensor network data, and sending them to parent node, then data are sent to gateway node from parent node directly or by router. After receiving the data from wireless sensor network, gateway node extracts data after analyzing and packaging them into Ethernet format data, sends them to the server. Less formally, any device that runs server software.

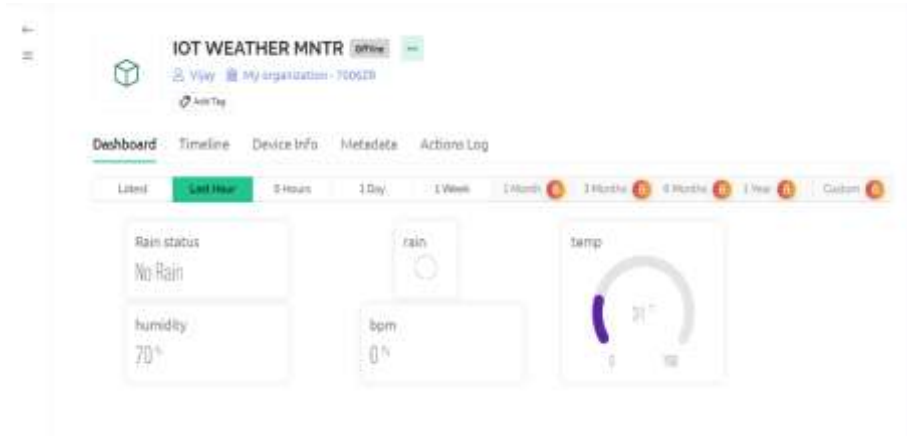

Figure.4 Blynk ouput on desktop

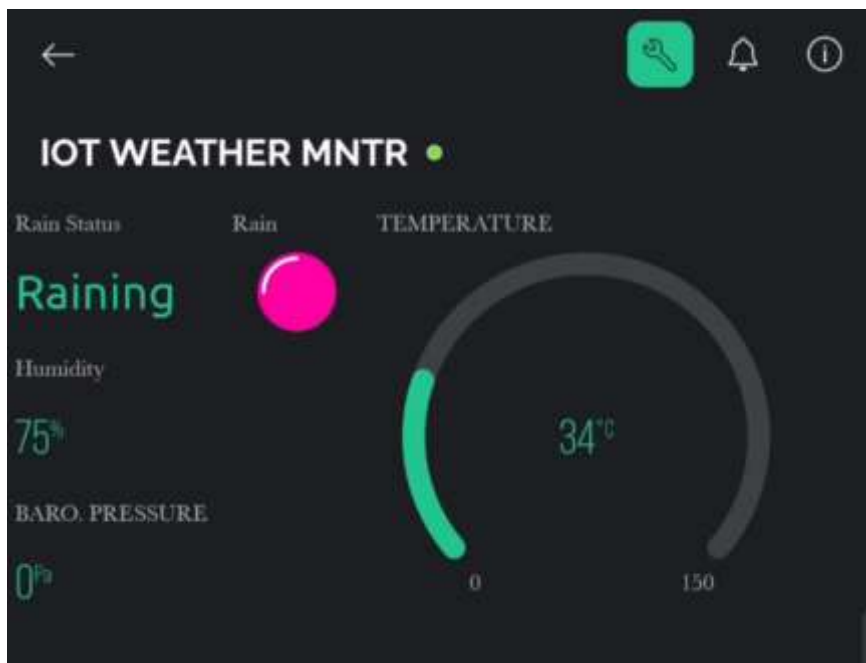

Figure.5 Blynk output on mobile

ADVANTAGES

- Real-time Monitoring
- Remote Accessibility
- Data Accuracy
- Cost Efficiency
- Integration Capabilities
- Predictive Analysis
- Smart Agriculture and Industry

APPLICATIONS

- Agriculture
- Transportation and Logistics
- Energy Management
- Construction and Infrastructure
- Retail and Tourism
- Healthcare

CONCLUSION

In conclusion, IoT-based weather monitoring systems represent a transformative technology with widespread applications across various sectors and industries. By leveraging sensors, connectivity, and data analytics, these systems provide real-time insights into weather conditions, enabling organizations to make informed decisions, optimize operations, and enhance safety and resilience.

From agriculture and transportation to smart cities and emergency management, IoT weather monitoring systems offer a multitude of benefits, including improved resource management, enhanced risk mitigation, and increased efficiency. By integrating weather data into decision-making processes, organizations can better anticipate and respond to weather-related challenges, such as extreme temperatures, storms, and natural disasters.

Despite their numerous advantages, IoT-based weather monitoring systems also present challenges, including reliability issues, security concerns, and technical complexity. Addressing these challenges requires careful planning, investment in infrastructure and resources, and ongoing monitoring and maintenance.

FUTURE SCOPE

Future advancements in sensor technology, data analytics, and machine learning algorithms will enable IoT weather monitoring systems to provide even more precise and accurate weather forecasts, with higher spatial and temporal resolutions.

It will increasingly integrate with smart infrastructure, such as smart buildings, smart grids, and intelligent transportation systems, to optimize resource management, improve energy efficiency, and enhance urban resilience.

The adoption of edge computing and artificial intelligence (AI) techniques will enable IoT weather monitoring systems to process and analyze data closer to the source, reducing latency, conserving bandwidth, and enabling real-time decision-making in resource-constrained environments.

It will continue to evolve into predictive analytics platforms, capable of forecasting extreme weather events, natural disasters, and climate-related risks with greater accuracy and lead time, enabling proactive mitigation measures and early warning systems.

It will find applications beyond traditional sectors, such as healthcare, retail, and insurance, where weather data can inform decision-making, influence consumer behavior, and mitigate risks related to weather-related disruptions and disasters.

Addressing privacy and security concerns will remain a priority for future IoT-based weather monitoring systems, with a focus on implementing robust data protection measures, ensuring user

consent and transparency and safeguarding sensitive weather data from unauthorized access and misuse.

REFERENCES

1. Madakam, S., Ramaswamy, R., & Tripathi, S. (2015). Internet of Things (IoT): A Literature Review. *Journal of Computer and Communications*, 3(05), 164-173. [1]
2. Gubbi, J., Buyya, R., Marusic, S., & Palaniswami, M. (2013). Internet of Things (IoT): A vision, architectural elements, and future directions. *Future Generation Computer Systems*, 29(7), 1645-1660. [2]
3. Li, S., Da Xu, L., & Zhao, S. (2015). The internet of things: a survey. *Information Systems Frontiers*, 17(2), 243-259. [3]
4. Jazdi, N. (2014). Cyber physical systems in the context of Industry 4.0. In 2014 IEEE International Conference on Automation, Quality and Testing, Robotics (pp. 1-4). IEEE. [4]
5. Ayyappan, S., & Ravichandran, C. S. (2019). A Review of Internet of Things (IoT) in Agriculture. *International Journal of Advanced Trends in Computer Science and Engineering*, 8(5), 2594-2598. [5]

6. Vujović, V., Savić, S., Matić, M., & Pokrajac, I. (2020). Review of modern technologies and tools for environmental monitoring and precision agriculture. *Journal of Environmental Management*, 265, 110554. [6]
7. Gaffar, A., Khelifi, A., Alzaabi, M., Al-Jaroodi, J., & Jawhar, I. (2018). An Overview of Internet of Things Based Real-Time Air Quality Monitoring Systems in Smart Cities. *IEEE Access*, 6, 10723-10741. [7]
8. Mahapatra, S., & Mohanty, S. P. (2017). IoT-based Weather Forecasting and Early Warning System. In *2017 2nd International Conference for Convergence in Technology (I2CT)* (pp. 398-403). IEEE. [8]
9. Razaque, A., Kifayat, K., & Shah, M. A. (2019). IoT based weather forecasting using machine learning. In *2019 2nd International Conference on Computer Applications & Information Security (ICCAIS)* (pp. 1-6). IEEE. [9]
10. Siddiqui, M. S., Nazir, S., & Saeed, S. (2019). IoT-Based Weather Monitoring System for Smart Agriculture. In *Proceedings of the 2019 3rd International Conference on Cloud and Big Data Computing* (pp. 21-25). ACM. [10]