

EFFICIENT AND ENHANCED AIR POLLUTION MONITORING AND CONTROLLING USING IOT

¹Venkateshwarlu G, ²Anitha A, ³Prabhavathamma Y

^{1,2}Assistant Professor, ³Associate Professor

Department of ECE

Tadipatri Engineering College, Tadipatri, AP

ABSTRACT:

The level of pollution has increased with times by lot of factors like the increase in population, increased vehicle use, industrialization and urbanization which results in harmful effects on human wellbeing by directly affecting health of population exposed to it. In order to monitor In this project we are going to make an IOT Based Air Pollution Monitoring System in which we will monitor the Air Quality over a web server using internet and will trigger a alarm when the air quality goes down beyond a certain level, means when there are sufficient amount of harmful gases are present in the air like CO₂, smoke and sound pollution sensor is attached to hardware to measure sound decibels. Further, this project is enhanced by measuring, monitoring and controlling the pollution parameters.

Keywords: Internet of Things, Air pollution index, Humidity, Temperature, Air quality, Carbon monoxide.

1.0 INTRODUCTION:

One of the most alarming issues in modern cities is the air quality level, where air pollution has caused 120 deaths out of 100,000 per year based on a worldwide study (Green Car Congress, 2019). The World Health Organization emphasized that 97% of cities in low- and middle- income countries with more than 100 000 inhabitants do not meet World Health Organization (WHO) air quality guidelines. Due to poor air quality, it will increase potential health risks such as risk of stroke, heart disease, lung cancer,

asthma and others as well (citation). Hence, there is a need to install an air quality monitoring system in cities to ensure the air is not contaminated. This can be done by installing sensors to monitor dust particles, carbon dioxide, carbon monoxide, nitrogen dioxide and sulfur dioxide levels and this information can be shared with the public through smartphones, where the smartphone app allows people to monitor real-time data of the current air quality level in the area. Hence, through these implementations, better quality of life can be achieved. Respiratory problems are very common among many people due to air pollution and toxic substance of air. Carbon monoxide, Carbon dioxide, Sulfur dioxide, Nitrogen dioxide, Lead are certain air pollutants commonly known as Criteria pollutants. Microbes, moulds, Animal skins, pets, insects are common among the biological pollutants. Air pollution is a major drawback of the current environment and it is a hindrance for public health. Air pollution causes many adverse health effects in human beings, other organisms, for environment, variations in climatic conditions and changes in life cycle of everything. Harmful gases in the air is the reason for all the effects mentioned above by which the entire world suffers a lot. IOT and artificial intelligence based systems will be much helpful for the monitoring of environment. Algorithms like ANN, CNN, KNN, SVM, Random Forest are pre dominantly used for the environment monitoring. The monitored data or

measured data is connected with Think Speak. The environment data obtained can be monitored from anywhere. Here Indoor Air Quality Check (IAQC) is considered for making a smart home with pollution free or pollution less. Air quality based on pollutants level which has the parameters like Carbon dioxide, Nitrogen dioxide, Sulfur dioxide etc. Temperature also has reverse effect on environment. Various sensor nodes integrated along with IAQC monitoring will have a better effect on air quality. This paper gives the comparison of various methods involved and better effect based on the proposed technique. Modified Navie bayes algorithm is proposed here to analyze and give the data.

2.0 LITEERATURE SURVEY:

The drawbacks of the conventional monitoring instruments are their large size, heavy weight and extraordinary expensiveness. These lead to sparse deployment of the monitoring stations. In order to be effective, the locations of the monitoring stations need careful placement because the air pollution situation in urban areas is highly related to human activities (e.g. construction activities) and location-dependent (e.g., the traffic choke-points have much worse air quality than average). IOT Based Air Pollution Monitoring System monitors the Air Quality over a webserver using internet and will trigger an alarm when the air quality goes down beyond a certain level, means when there are amount of harmful gases present in the air like CO₂, smoke, alcohol, benzene, NH₃, NO_x and LPG. The system will show the air quality in PPM on the LCD and as well as on webpage so that it can be monitored very easily. Temperature and Humidity is detected and monitored in the system. LPG gas is detected using MQ6 sensor and MQ135 sensor is used for monitoring Air

Quality as it detects most harmful gases and can measure their amount accurately. In this IOT project, it can monitor the pollution level from anywhere using your computer or mobile. This system can be installed anywhere and can also trigger some device when pollution goes beyond some level, like we can send alert SMS to the user. A wireless distributed mobile air pollution monitoring system using General Packet Radio Service (GPRS) sensors was reported in [7]. Advancements in wireless communication and sensor technology are rapidly changing air pollution monitoring paradigm [8].

3.0 PROPOSED METHOD:

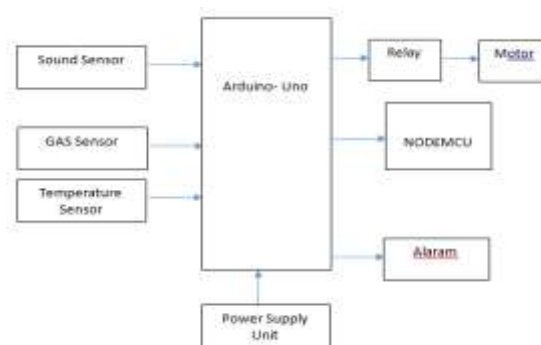

Fig1: Proposed block diagram

ARDUINO-UNO:

Arduino is a prototype platform (open-source) based on an easy-to-use hardware and software. It consists of a circuit board, which can be programmed (referred to as a microcontroller) and a ready-made software called Arduino IDE (Integrated Development Environment), which is used to write and upload the computer code to the physical board.

Arduino provides a standard form factor that breaks the functions of the microcontroller into a more accessible package

Arduino is a prototype platform (open-source) based on an easy-to-use hardware and software. It consists of a circuit board, which can be programmed (referred

to as a microcontroller) and a ready-made software called Arduino IDE (Integrated Development Environment), which is used to write and upload the computer code to the physical board.

The key features are –

- Arduino boards are able to read analog or digital input signals from different sensors and turn it into an output such as activating a motor, turning LED on/off, connect to the cloud and many other actions.
- You can control your board functions by sending a set of instructions to the microcontroller on the board via Arduino IDE (referred to as uploading software).
- Unlike most previous programmable circuit boards, Arduino does not need an extra piece of hardware (called a programmer) in order to load a new code onto the board. You can simply use a USB cable.
- Additionally, the Arduino IDE uses a simplified version of C++, making it easier to learn to program.
- Finally, Arduino provides a standard form factor that breaks the functions of the microcontroller into a more accessible package.

NODEMCU ESP8266:

The ESP8266 series, or family, of Wi-Fi chips is produced by Espressif Systems, a fabless semiconductor company operating out of Shanghai, China. The ESP8266 series presently includes the ESP8266EX and ESP8285 chips.

ESP8266EX (simply referred to as ESP8266) is a system-on-chip (SoC)

which integrates a 32-bit Tensilica microcontroller, standard digital peripheral interfaces, antenna switches, RF balun, power amplifier, low noise receive amplifier, filters and power management modules into a small package. It provides capabilities for 2.4 GHz Wi-Fi (802.11 b/g/n, supporting WPA/WPA2), general-purpose input/output (16 GPIO), Inter-Integrated Circuit (I²C), analog-to-digital conversion (10-bit ADC), Serial Peripheral Interface (SPI), I²S interfaces with DMA (sharing pins with GPIO), UART (on dedicated pins, plus a transmit-only UART can be enabled on GPIO2), and pulse-width modulation (PWM). The processor core, called "L106" by Espressif, is based on Tensilica's Diamond Standard 106Micro 32-bit processor controller core and runs at 80 MHz (or overclocked to 160 MHz). It has a 64 KiB boot ROM, 32 KiB instruction RAM, and 80 KiB user data RAM. (Also, 32 KiB instruction cache RAM and 16 KiB ETS system data RAM.) External flash memory can be accessed through SPI. The silicon chip itself is housed within a 5 mm × 5 mm Quad Flat No-Leads package with 33 connection pads — 8 pads along each side and one large thermal/ground pad in the center.

The ESP8266 is a System on a Chip (SoC), manufactured by the Chinese company Espressif. It consists of a Tensilica L106 32-bit **micro controller** unit (MCU) and a **Wi-Fi transceiver**. It has **11 GPIO pins*** (General Purpose Input/Output pins), and an **analog input** as well. This means that you can program it like any normal Arduino or other microcontroller. And on top of that, you get Wi-Fi communication, so you can use it to connect to your Wi-Fi network, connect to the Internet, host a web server with real web pages, let your smartphone connect to it, etc ... The possibilities are endless! It's no wonder

that this chip has become the most popular IOT device available.

The ESP8266 WiFi Module is a self-contained SOC with integrated TCP/IP protocol stack that can give any microcontroller access to your WiFi network. The ESP8266 is capable of either hosting an application or offloading all Wi-Fi networking functions from another application processor. Each ESP8266 module comes pre-programmed with an AT command set firmware, meaning, you can simply hook this up to your Arduino device and get about as much WiFi-ability as a WiFi Shield offers (and that's just out of the box)! The ESP8266 module is an extremely cost effective board with a huge, and ever growing, community.

This module has a powerful enough on-board processing and storage capability that allows it to be integrated with the sensors and other application specific devices through its GPIOs with minimal development up-front and minimal loading during runtime. Its high degree of on-chip integration allows for minimal external circuitry, including the front-end module, is designed to occupy minimal PCB area. The ESP8266 supports APSD for VoIP applications and Bluetooth co-existence interfaces, it contains a self-calibrated RF allowing it to work under all operating conditions, and requires no external RF parts.

MQ2 SENSOR:

MQ2 is one of the commonly used gas sensors in MQ sensor series. It is a Metal Oxide Semiconductor (MOS) type Gas Sensor also known as Chemiresistors as the detection is based upon change of resistance of the sensing material when the Gas comes in contact with the material. Using a simple voltage divider network, concentrations of gas can be detected.



Fig2: GAS sensor

MQ2 Gas sensor works on 5V DC and draws around 800mW. It can detect LPG, Smoke, Alcohol, Propane, Hydrogen, Methane and Carbon Monoxide concentrations anywhere from 200 to 10000ppm.

SOUND SENSOR:

The sound sensor is a small board that combines a microphone (50Hz-10kHz) and some processing circuitry to convert sound waves into electrical signals.

This electrical signal is fed to on-board LM393 High Precision Comparator to digitize it and is made available at OUT pin.

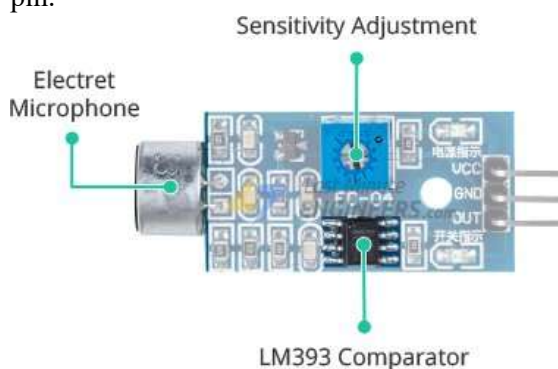

Fig 3: Sound Sensor

- The module has a built-in potentiometer for sensitivity adjustment of the OUT signal.
- You can set a threshold by using a potentiometer; So that when the amplitude of the sound exceeds the threshold value, the module will output LOW otherwise HIGH.
- This setup is very useful when you want to trigger an action when

certain threshold is reached. For example, when the amplitude of the sound crosses a threshold (when a knock is detected), you can activate a relay to control the light. You got the idea!

4.0 TEMPERATURE SENSOR LM35:

The Temperature Sensor LM35 series are precision integrated-circuit temperature devices with an output voltage linearly proportional to the Centigrade temperature.

The LM35 device has an advantage over linear temperature sensors calibrated in Kelvin, as the user is not required to subtract a large constant voltage from the output to obtain convenient Centigrade scaling. The LM35 device does not require any external calibration or trimming to provide typical accuracies of $\pm 1/4^{\circ}\text{C}$ at room temperature and $\pm 3/4^{\circ}\text{C}$ over a full -55°C to 150°C temperature range.

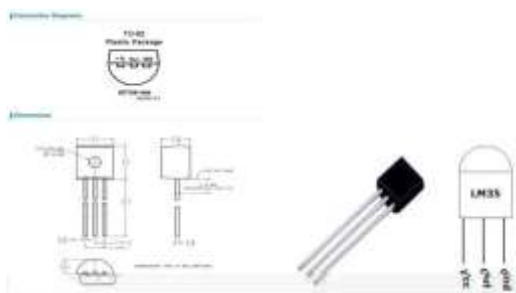

Fig4: Temperature sensor

VIBRATION MOTOR:

A vibration motor is a motor which vibrates when given sufficient power. It is a motor that literally shakes.

It is very good for vibrating objects. It can be used in a number of devices for very practical purposes. For example, one of the most common items that vibrate are cell phones that vibrate when called when placed in vibration mode. A cell phone is such an example of an electronic device that contains a vibration motor. Another example can be a rumble pack of a game

controller that shakes, imitating the actions of a game. One controller where a rumble pack could be added as an accessory is nintendo 64, which came with rumble packs so that the controller would vibrate to imitate gaming actions. A third example could be a toy such as a furby that vibrates when you a user does actions such as rub it or squeeze it, etc.

So vibration motor circuits have very useful and practical applications that can serve a myriad of uses.

To make a vibration motor vibrate is very simple. All we have to do is add the needed voltage to the 2 terminals. A vibration motor has 2 terminals, usually a red wire and a blue wire. The polarity does not matter for motors.

For our vibration motor, we will be using a vibration motor by Precision Microdrives. This motor has an operating voltage range of 2.5-3.8V to be powered.

So if we connect 3 volts across its terminal, it will vibrate really well, such as shown below:

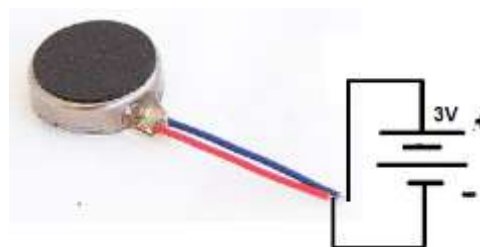

Fig5: Vibration motor



Fig 6: Proposed hardware model

CONCLUSION:

The system to monitor the air of environment using Arduino microcontroller, IOT Technology is

proposed to improve quality of air. With the use of IOT technology enhances the process of monitoring various aspects of environment such as air quality monitoring issue proposed in this paper. Here using of multiple sensors, gives the different type of dangerous signals and Arduino is the heart of this project which controls the entire process. Nose MCU module connects the whole process to internet and. The air & sound monitoring system overcomes the problem of the highly-polluted areas which is a major issue. It supports the new technology and effectively supports the healthy life concept. This system has features for the people to monitor the amount of pollution on their mobile phones using the application.

FUTURE SCOPE

The future scope is that device which we are having can be done in an compact way by reducing the size of the device For further implementation or the modifications which can be is that detecting the vehicles amount of pollution which can be determined. In future the range can be made increased according to the bandwidth for the high range frequencies. Further research can be made by making the people in the right direction for their welfare. Therefore, there is another beneficiary by using this device in an app so the all can be used in an GSM mobile phones for their daily updates by increasing their range.

REFERENCES

1. B. C. Kavitha, D. Jose, and R. Vallikannu, "IoT based pollution monitoring system using raspberry-PI," *International Journal of Pure and Applied Mathematics*, vol. 118, 2018. View at: [Google Scholar](#)
2. D. Saha, M. Shinde, and S. Thadeshwar, "IoT based air quality monitoring system using wireless sensors deployed in public bus services," in *ICC '17 Proceedings of the Second International Conference on Internet of things, Data and Cloud Computing*, Cambridge, United Kingdom, March 2017. View at: [Publisher Site](#) | [Google Scholar](#)
3. J. Liu, Y. Chen, T. Lin et al., "Developed urban air quality monitoring system based on wireless sensor networks," in *2011 Fifth International Conference on Sensing Technology*, pp. 549–554, Palmerston North, New Zealand, December 2011. View at: [Publisher Site](#) | [Google Scholar](#)
4. United States Environmental Protection Agency, *Managing air quality - air pollutant types*, October 2018, <https://www.epa.gov/air-quality-management-process/managing-air-quality-air-pollutant-types>.
5. C. Arnold, M. Harms, and J. Goschnick, "Air quality monitoring and fire detection with the Karlsruhe electronic micronose KAMINA," *IEEE Sensors Journal*, vol. 2, no. 3, pp. 179–188, 2002. View at: [Publisher Site](#) | [Google Scholar](#)
6. S. Abraham and X. Li, "A cost-effective wireless sensor network system for indoor air quality monitoring applications," *Procedia Computer Science*, vol. 34, pp. 165–171, 2014. View at: [Publisher Site](#) | [Google Scholar](#)
7. O. A. Postolache, D. J. M. Pereira, and S. P. M. B. Girão, "Smart sensors network for air quality monitoring applications," *IEEE Transactions on Instrumentation and Measurement*, vol. 58, no. 9, pp. 3253–3262, 2009. View at: [Publisher Site](#) | [Google Scholar](#)
8. Y. Jiangy, K. Li, L. Tian et al., "MAQS: a personalized mobile sensing system for indoor air quality monitoring," in *Proceedings of the 13th international conference on Ubiquitous computing*, pp. 271–280, Beijing, China, September 2011. View at: [Publisher Site](#) | [Google Scholar](#)
9. S. Bhattacharya, S. Sridevi, and R. Pitchiah, "Indoor air quality monitoring

- using wireless sensor network,” in *2012 Sixth International Conference on Sensing Technology (ICST)*, pp. 422–427, Kolkata, India, December 2012. View at: [Publisher Site](#) | [Google Scholar](#)
10. S. Zampolli, I. Elmi, F. Ahmed et al., “An electronic nose based on solid state sensor arrays for low-cost indoor air quality monitoring applications,” *Sensors and Actuators B: Chemical*, vol. 101, no. 1-2, pp. 39–46, 2004. View at: [Publisher Site](#) | [Google Scholar](#)