

## FUZZY BASED THD REDUCTION USING DYNAMIC VOLTAGE RESTORER FOR POWER QUALITY IMPROVEMENT

<sup>1</sup>Gorla Sunilkumar Reddy,<sup>2</sup>Arekallu Nagamani,<sup>3</sup>Gaddam Padmavathi

<sup>1,2</sup>Assistant Professor,<sup>3</sup>Associate Professor

Department Of EEE

Tadipatri Engineering College, Tadipatri, AP

**ABSTRACT:** Power Quality is an essential concern in the modern power system that can affect consumers and utility. The integration of renewable energy sources, smart grid systems and extensive use of power electronics equipment caused myriad problems in the modern electric power system. Current and voltage harmonics, voltage sag, and swell can damage the sensitive equipment. These devices are susceptible to input voltage variations created by interference with other parts of the system. Hence, in the modern age, with an increase in sensitive and expensive electronic equipment, power quality is essential for the power system's reliable and safe operation. Dynamic Voltage Restorer (DVR) is a potential Distribution Flexible AC Transmission System (D-FACTS) device widely adopted to surmount the problems of non-standard voltage, current, or frequency in the distribution grid. It injects voltages in the distribution line to maintain the voltage profile and assures constant load voltage. The simulations were conducted in MATLAB/Simulink to show the DVR-based proposed strategy's effectiveness to smooth the distorted voltage due to harmonics. A power system model with a programmable power source is used to include 3rd and 5th harmonics. The systems' response for load voltage is evaluated for with and without DVR scenarios. It has been noted that the proposed DVR based strategy has effectively managed the voltage distortion, and a smooth compensated load voltage was achieved. The load voltage THD percentage was approximately 18% and 23% with insertion 3rd and 5th harmonics in the supply voltage, respectively. The inclusion of the proposed DVR has reduced THD around less than 4% in both cases.

**INDEX TERMS:** Dynamic voltage restorer, FACTS, total harmonic distortion, sag, swell, harmonics

### 1. INTRODUCTION

Electrical Energy is invisible, a universal commodity that is immediately available in most of the world, and it has now been recognized as everyday consumer need [1]. Renewable Energy Systems (RESs) is used to aid the primary energy demand in solar, Solar thermal, wind energy, etc. The

intermittent nature of RESs, harmonics, and reactive power problems halt the power system's performance by originating stability concerns in the power system [2], [3]. The Flexible AC Transmission Systems (FACTS) devices are widely adapted for reactive power compensation, voltage stability, and power quality in distribution grids around the world [4], [5]. However, FACT devices also alter different parameters on the transmission and distribution system [6].

This work presents a study of the power quality and aims at identifying the causes of poor power quality and provide the solutions to these power quality problems. Some equipment like computers, laptops, relays, solid-state devices, adjustable speed drives, and optical devices are known as sensitive equipment. These devices are susceptible to input voltage variations created by interference with other parts of the system. The power system is divided into the following parts as generation, transmission, distribution, and by using other transmission line power systems is fed to different loads on the distribution side. Power quality plays a vital role in the power system when variable power is supplied to the load. Subsequently, the domestic and industrial customers with delicate loads are affected by the poor quality of power. Even there is various type of load on the distribution side, but poor power quality affects the sensitive loads more than others. There are many applications where the sensitive load has an increasing demand, like in hospital's operation theatres, semiconductor systems in processing plants, database systems, instruments to control air pollution in crowded areas, precise and accurate equipment are required by data processing, and service providers. If the power system causes the dips and distorted voltages, these devices may fail, and such a device's failure leads to wastage of a significant amount of money. Therefore, the distribution side is dependent on power quality. Electrical characteristics are set by the power system that does not disturb the system's performance and perform its function in a controlled manner. In this article, voltage swell and distorted voltage with high harmonics in it are discussed. When the load voltage being disturbed, it causes

voltage sag, transient, swell, and high distorted voltage with harmonics and Total Harmonic Distortion (THD) due to the occurrence of the faults. The vulnerability of voltage sags and harmonics problems is mostly to the delicate instruments. Few problems occur in the result of voltage sag that may also cause disturbance of torques in the motors, device burning, misfiring in the device, etc. The harmonic is an essential issue for power quality to be solved effectively. When the faults occur in the power system that causes a large current drawn from the power system, a short duration reduction RMS voltage appears, commonly known as voltage sag or Dips [7]. For example, when someone starts an air conditioner or a heavy motor, the startup of the load and remote fault clearance done by utility instrument, are the fundamental cause of sag production. When the motor starts, it causes six times more current than actual current. While the motor's startup, a substantial amount of reactive power is absorbed that will lead to the introduction of voltage sag. The voltage profile of the voltage sag is presented in Figure 1.

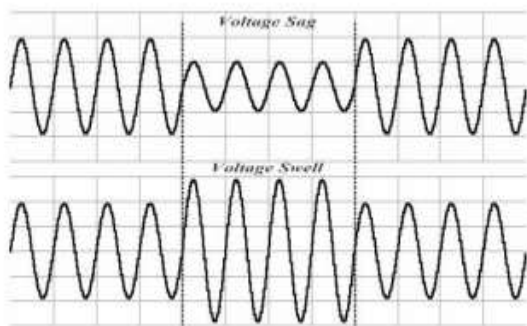

FIGURE 1. Voltage waveform with sag and swell [7].

Voltage swell is defined as the increase in the voltage value from its fundamental value, e.g., during the half-cycle to 1-minute time, the change in voltage from 10 to 80 %. Similarly, it causes overvoltage when voltage sag, continued increasing voltage profile. There are different types of voltage swell, including i. Instantaneous swell, ii. Momentary swell, and iii. Temporary swell. When the connection of large loads being disturbed, it also causes voltage swell. An increase in voltage of the faulted phase and natural wire's loose connection causes resultant to Single Line to Ground fault (SLG). Overheating and destruction of electrical instruments and insulation breakdown are consequences of voltage swells. Figure 1 shows the voltage swell in voltage profile. Harmonic distortion is the problem of voltage produced by the variation in fundamental frequencies by three times, for example, 50Hz fundamental frequency when multiplying with three as  $3 \times 50 = 150\text{Hz}$ . That is the 3rd harmonic of the fundamental

frequency, as Figure 2 shows the waveform with harmonic content. The function of switching in power electronics causes harmonics creation. The tripping of circuit breakers, overheating of neutral conductors, transformers, and other power distribution instruments, destruction of circuits without proper management based on clear sine wave activates at zero crossover point are the indicators of a harmonic issue [3], [8].

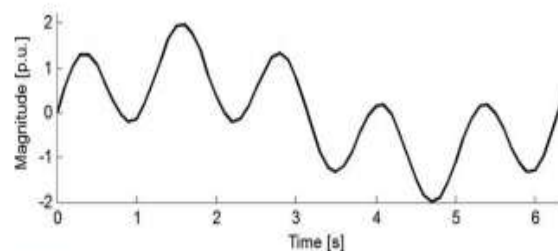

FIGURE 2. Waveform with harmonic content [7].

The main contributions of this research work are summarized below: • to decrease the THD lower than 5% by mitigating the problem of distorted voltage due to sags, swell or, harmonics. • to access and analyze the performance of the suggested model with the use of MATLAB / SIMULINK along with the use of DVR and without it too. • to investigate the power system with the insertion of 3rd and 5th harmonics in the input voltage profile. • to evaluate the performance of the DVR based power system with same 3rd and 5th harmonics insertion by comparing its results with without DVR based system.

## II. LITERATURE REVIEW OF DVR

The transmission and distribution system problems were addressed in some countries using the FACTS and D-FACTS devices. As per IEEE recommendations, FACTS can be expressed as [9], "AC transmission systems containing static and power electronics-based controllers to increase power transfer capability and more immeasurable controllability." Today, electricity demand has risen considerably while the development of generation and transmission systems is not adequate by the limited resources, economic issues, and some environmental limitations. The present transmission system cannot be easily extended due to limited resources. Therefore, the expansion in transmission capacity is a viable solution. Transmission lines are not being fully utilized due to some limiting factors affecting the loading capability of the transmission line. These factors are perceived as the thermal limit, dielectric, and stability. FACTS controllers can control power and enhance the usable capacity of present lines. The FACTS controllers enable the power to flow through line under normal conditions and when subjected to faults and allow a line to transport power close to its thermal ratings [10], [11].

DVR is used on the distribution feeder to protect the load from faults due to the voltage sags and voltage swells. DVR is mounted in series with the load, and a battery energy storage system (BESS) is connected with a transformer and inverter are also connected with DVR, which compensate the active and reactive power requirement for the reduction in voltage sags and voltage swells [12]. For the voltages stability, DVR injects voltage into the distribution system, the DVR to the system through the transformer. DVR is the FACTS device, which compensates the disturbances like the voltage sags, swells, and voltages harmonics from the loads. DVR injects the voltages in series with the transmission lines and injects a small amount of voltages in normal conditions. But, when a disturbance occurs, DVR calculates the voltages required to protect the load through the sinusoidal pulse width modulation (SPWM). Then after those voltages are injected in the system to maintain the situation. In the steady-state, DVR either absorbs or delivers the active or reactive power, but when a disturbance occurs, DVR delivers or absorbed the active or reactive power from the dc-link [13]. Martiningsih et al. have recommended the installation of DVR are PT DSS power plant, the DVR acts as a compensator and connected in series with the distribution line. The proposed PI-based DVR is competent in restoring the power quality restraint. [14]. Eltamaly et al. have proposed a DVR based strategy for mitigation of voltage sag through DVR to enhance the power systems quality. To degradation in the performance of electrical equipment. The results determine that DVR compensate sag/swell adequately and implement proper voltage adjustment [15]. Ali et al. have proposed a novel DVR with a power electronic transformer (PET) to mitigate the symmetrical and asymmetrical sags and swells. The results depict that the novel design is effectively alleviates the symmetrical and asymmetrical voltage sag and voltage swell on the distribution line [16]. A nonlinear adaptive control (NAC) with DVR is proposed to recover the Low Voltage Ride Through (LVRT) for a renewable power system. Real perturbation of the system is compensated by the estimating the perturbation with the NAC in which the parameter which includes measurement of the noise, uncertainties, and disturbances such as the intermittent effect of the renewable sources and grid faults. Through the NAC, no precise model and complete measurement are required for robust and adaptive control. The DVR is embedded with the energy storage system (ESS). ESS-DVR compensates the grid voltage dips for supporting the voltages. In that scenario, the fuzzy logic controller (FLC) can be used, and both FLC and NAC based controller

enhance the LVRT capability [17]. The main thing is that a high rating of the ESS-DVR is required if it is low. The performance will be reduced. Another FLC based power quality improvement strategy for DVR was proposed was Benali et al. [18]. Danbumrungrakul et al. have presented a using zero active power technique for enhancing the performance of DVR [19]. They have obtained superior results with their prospered method than the conventional In-Phase Compensation with DVR. A power quality improvement technique using a Grasshopper Optimization Algorithm (GOA) based DVR is presented in [20]. A GOA based technique is recommended to tune the parameters of convention Proportional Integral Derivative (PID) controller. A comparison of literature available on DVR and its applications is presented in Table 1.

TABLE 1. A comparison of various DVR based approaches.

Type	Control Strategy	Application	Reference
DVR-ESS	FLC and NAC	LVRT	[17]
DVR-OLTC	On-load tap changing transformer	Regulation of voltages, power flow	[21]
DVR	DVR system with DSP control board	Power source, SW5250A/ELGAR	[15]
DVR	PI	PT, DSS Power Plant	[14]
Novel DVR	No control	Power electronic transformer (PET) based DVR	[16]
DVR	FLC	Hybrid Wind-PV LVRT	[18]
DVR	Zero-real power tracking technique	Power system voltage sag and swell	[19]
DVR	GOA based PID	voltage sag and swell	[20]

### III. POWER QUALITY

The contemporary container crane industry, like many other industry segments, is often enamored by the bells and whistles, colorful diagnostic displays, high speed performance, and levels of automation that can be achieved. Although these features and their indirectly related computer based enhancements are key issues to an efficient terminal operation, we must not forget the foundation upon which we are building. Power quality is the mortar which bonds the foundation blocks.

Power quality also affects terminal operating economics, crane reliability, our environment, and initial investment in power distribution systems to support new crane installations. To quote the utility company newsletter which accompanied the last monthly issue of my home utility billing: 'Using electricity wisely is a good environmental and business practice which saves you money, reduces emissions from generating plants, and conserves our natural resources.' As we are all aware, container crane performance requirements continue to increase at an astounding rate.

Next generation container cranes, already in the bidding process, will require average power demands of 1500 to 2000 kW – almost double the total average demand three years ago. The rapid increase in power demand levels, an increase in container crane population, SCR converter crane drive retrofits and the large AC and DC drives needed to power and control these cranes will increase awareness of the power quality issue in the very near future.

**IV.CONSTRUCTION OF DVR**

There are two parts of the DVR: one is the power circuit, and the other is the control circuit. The control signal consists of magnitude, phase shift, the frequency that are complex parameters of it, and injected by the DVR system. In the power circuit, the switches are used to generate a voltage-dependent on control signals. Additionally, this section will describe the fundamental structure of the DVR by the power circuit. The construction and basic Configuration of the DVR are shown in Figure 4 [27].

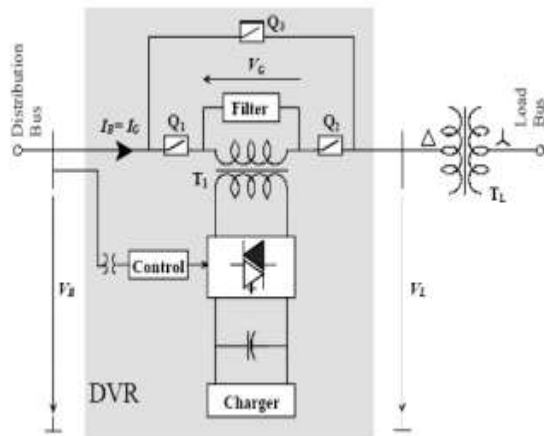

**FIGURE 3.** Principle design of DVR connected at distribution end [15].

1) ENERGY STORAGE UNIT Different devices are used to store energy like Flywheels, Lead-acid batteries, Superconducting Magnetic energy storage (SMES), and Super-Capacitors [28]. While the occurrence voltage sags, the storage unit provides the required real power as it is its primary function. The compensation capability of DVR is defined by the active power produced the device of energy storage. Instead of using other storage devices, the devices of the high response time of charging and discharging are being used that are lead batteries. The rate of discharge determines the internal space available for the storage of energy, and

this discharging rate is based on a chemical reaction [29], [30].

2) VOLTAGE SOURCE INVERTER The use is of Pulse-Width Modulated VSI (PWMVSI) widespread. A DC voltage has been created through a device of energy storage, as discussed in the previous section. A VSI is the source of the conversion of voltage from DC-AC voltage. At the time of sag occurrence, a step-up voltage injection transformer of the DVR power circuit has been used to increase the magnitude of voltage. So, a minimum voltage value with VSI is enough.

3) PASSIVE FILTERS The use of low passive filters in this method in which the PWM inverted pulse waveform converted into a sinusoidal waveform. In VSI for the achievement of this conversion, it is compulsory to remove high-value harmonic components while DC-AC transformation, and it will also change the compensated output voltage. A passive filter is an essential source in voltage inverter. That is why it uses either on the side of low voltage like the inverter side of the injection transformer and side of high voltage like load side, as shown in Figure 5. If we put the filters on the inverter side, it can overcome maximum value harmonics from passing through the voltage transformer. So, the stress on the injection transformer is also decreased by it. When the filter is placed in the inverter side and causes phase shift and voltage drop in inverted, that is the disadvantage of the filter. Thus, by putting the filter on the load side, this problem can be solved. The secondary side of the transformer permits the high valued harmonics currents because the transformer with high values is necessary.

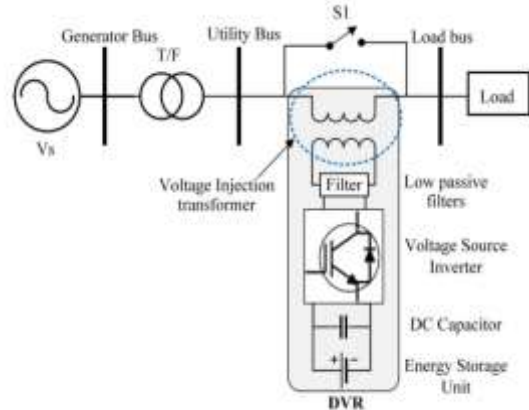

**FIGURE 4.** Basic Configuration of DVR.

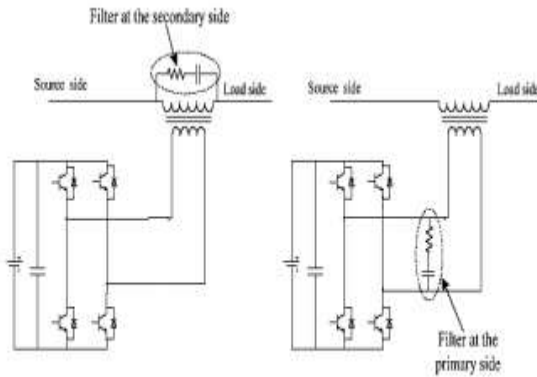

FIGURE 5. Different filter placements in DVR [15].

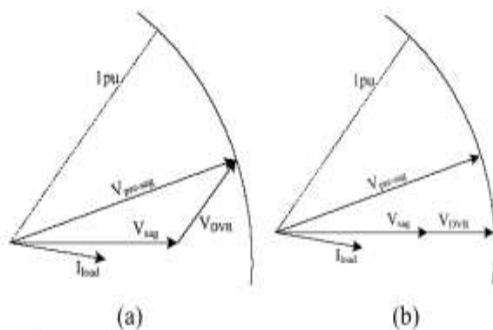

FIGURE 6. (a) Pre-sag compensation techniques, and (b) In-phase compensation techniques.

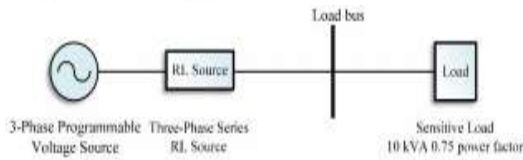

FIGURE 7. Single line diagram of test system without DVR.

#### 4) BY-PASS SWITCH

DVR is a series-connected device. The current pass through the inverter if the fault exists in the downstream causes a fault current. For the protection of the inverter, the By-pass switch is being used. Commonly, to bypass the inverter circuit, a crowbar switch is used. Whenever the current is in the range of parts of the inverter, the crowbar would detect the scale of the current and deactivate it in the end. On the other side, it will allow bypassing the components of the inverter if the current is high [15].

#### V.HARMONICS

The typical definition for a harmonic is “a sinusoidal component of a periodic wave or\ quantity having a frequency that is an integral multiple of the fundamental frequency.” [1]. Some references refer to “clean” or “pure” power as those without any harmonics. But such clean waveforms typically only exist in a laboratory.

Harmonics have been around for a long time and will continue to do so. In fact, musicians have been aware of such since the invention of the first string or woodwind instrument. Harmonics (called “overtones” in music) are responsible for what makes a trumpet sound like a trumpet, and a clarinet like a clarinet.

Electrical generators try to produce electric power where the voltage waveform has only one frequency associated with it, the fundamental frequency. In the North America, this frequency is 60 Hz, or cycles per second. In European countries and other parts of the world, this frequency is usually 50 Hz. Aircraft often uses 400 Hz as the fundamental frequency. At 60 Hz, this means that sixty times a second, the voltage waveform increases to a maximum positive value, then decreases to zero, further decreasing to a maximum negative value, and then back to zero. The rate at which these changes occur is the trigometric function called a sine wave, as shown in figure 1. This function occurs in many natural phenomena, such as the speed of a pendulum as it swings back and forth, or the way a string on a voiilin vibrates when plucked.

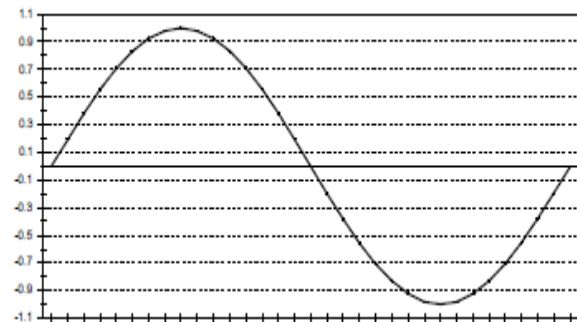

#### VI. PROPOSED DESIGN AND CONTROL PROPOSED DYNAMIC VOLTAGE RESTORER

The frequency of the supplied voltage can determine the power supply quality that is a significant indicator of power quality. The voltage sag is interpreted as a drop in the Root Mean Square (RMS) value of the voltage that can happen from 10 ms to 60 seconds with the depth of the falling voltage of 0.9 per unit (p.u) 0.1 p.u of a nominal p.u based on the IEEE standards. Regular voltage sags are usually checked for the load at the distribution level due to different reasons. The voltage sags are highly unbearable for a few delicate loads in high technology sectors. The load voltage requirements could be maintained by the complicated tasks with a specific frequency and exact value of voltage sag while distortion and oscillation. Usually, the

destruction of the production sector and its downtime is the result of voltage sag that is costly and leads to harsh problems among consumers. A specific amount of energy and voltage is supplied to the distribution system by using electric devices that are also named consumer power devices. The complex problem could be mitigated. As compared to the conventional methods of voltage sags problem solving, the DVR is supposed to be an efficient method to control the voltage sag and distortion. In this work, the power system's performance is evaluated by removing voltage sag through a DVR at the distribution level.

**A. PRINCIPLES OF DVR OPERATION**

A DVR is consists of GTO or IGBT based Voltage Source Inverter (VSI), an energy storage instrument, a capacitor bank, and an injection transformer. The DVR is also called solid-state power electronic switching device. A DVR connected to a distribution bus is illustrated in Figure 3. The practical guideline of the DVR as it works by methods for an injecting transformer; a control voltage is created by a forced commuted converter, which is in arrangement to the bus voltage. Different converter control topologies for droop-controlled converter are presented in [25], [26]. DC voltage source behaves like a device of energy storage given by the DC capacitor, as shown in Figure 4.

To mitigate the problem of voltage drop is not efficiently done by the DVR when there is no voltage sag issue under optimal conditions. DVR will produce a needed controlled voltage of high frequency with the existence of a distribution system, a required phase angle that will ensure that load is perfect and maintained. For keeping the consistency in the load supply of voltage in this situation, the capacitor will be discharged. Here is needed to note that the DVR can absorb and produce reactive power, but an external source of energy is used to provide reactive power injection. The voltage sag detection time and the devices of power electronics shorten the response time of DVR. As compared to the conventional methods of voltage correlation, for example, the tap-changing transformers response time of DVR is less than 25 milliseconds.

**VOLTAGE INJECTION TRANSFORMERS**

There are two sides of the voltage injection transformer, as one is the primary side linked with a distribution line in a series. The other one is the secondary side that is connected with the power circuit of DVR. For the three-phase DVR, one 3-phase transformer or three single-phase transformers could be used, but for one phase DVR, only one single-phase transformer is allowed. The ‘‘Delta-Delta’’ type connection is being used at the time of

contact between 3 phase DVR and three single-phase transformers [31]. Usually, the amount of voltage that is supplied by the filtered VSI output to a needed range also simulates the DVR circuit from the transformation network caused by the setup transformer. According to the required voltage at the secondary side of voltage, the pre-examined and significant values are winding ratios. The parts of inverter circuits are affected by the high cost of winding ratio with high-frequency currents—the primary side current with high-frequency ratios of high windings that could affect the parts of the inverter circuit. The value of the transformer is an important reason when determining the working efficiency of the DVR. The significance of the winding ratio of the injection transformer concerns on the upward distribution transformer. If there should arise an occurrence of a 1-Y association with the grounded unbiased, there won't be any zero-grouping current streaming into the auxiliary during an unbalance deficiency or an earth shortcoming in the high voltage side. In this manner, just the positive and negative arrangement segments are rewarded by the DVR [32].

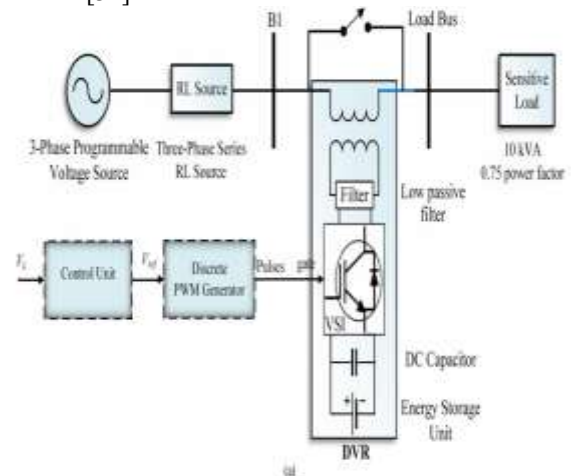

FIGURE 8. (a) Single line diagram of test system with DVR

TABLE 2. Parameters and values of test system.

Parameters	Values
Supply Voltage	415 kV
Frequency	50 Hz
Load Power Factor	0.74
Converter	IGBT (3arm-6 pulses)
Load active power	7.5 kW
Load reactive power	6.6 kVA

TABLE 3. THD% of test system with and without DVR.

Phases	Scenario 1 THD (%)		Scenario 2 THD (%)	
	without DVR	with DVR	without DVR	with DVR
Phase A	18.49	2.69	22.56	4.06
Phase B	18.49	2.40	22.56	3.55
Phase C	18.50	2.69	22.57	3.74

### C. OPERATING MODES

1) A VOLTAGE SAG/SWELL ON THE LINE The energy sources elements are used to supply the store power and use reactive energy to inject the power in DVR when there is variance among the pre sag voltage and the sag voltage. The maximum capacity of DVR is constrained as a result of the estimations of putting away DC energy and the ratio of voltage insertion transformer. In the circumstance of 3 single-phase DVRs, the degree of the injected voltage can be estimated individually. The injected voltages are being composed as comparable frequency and phase angle with the system voltages [33].

2) IN NORMAL FUNCTIONING DVR would not inject voltage to the load when there is no sag presence during the normal process. The device will run in self-charging means or as standby means if the power storage device is ultimately charged. There are various sources of self-supply for which the device of energy storage could be charged. 3) A SHORT CIRCUIT OR FAULT A bypass switch will be simulated during the downstream movement of the distribution line, and to prevent the inverter's electric parts, it will bypass the inverter circuit [15].

### D. COMPENSATION TECHNIQUES

1) PRE-SAG COMPENSATION It is a process that is used for the nonlinear loads, for example, thyristor-controlled drives. The compensation of phase angle and magnitude of voltage is done in nonlinear loads. The method of pre-sag compensation is presented in Figure 6 (a). For this method, a voltage injection transformer and an energy storage device with high value is required.

2) IN-PHASE COMPENSATION The in-phase compensation method is used for the active loads. There is a requirement of compensation only for voltage magnitude but not for phase angle compensation. The voltage in compensated form is in phase with sagged voltage in this method. For the compensation and support of DVR in terms of power storage devices, the process is suggested in Figure 6 (b), it is used when both the real and reactive powers are required.

## VII.SIMULATION RESULTS AND DISCUSSION

Simulations are performed on Intel (R) Core(TM) i5-7200U @ 2.5 GHz and window 10 operating system. MATLAB/Simulink software environment is adapted to perform the analysis of the proposed setup. The load of 10 kVA with 0.75 power factor is considered as a sensitive load. The sensitive load is supplied by the 415V load and 50Hz frequency to a 3-phase supply system. The single line diagram of the test system without DVR is shown in Figure 7. It shows that the test system contains a Three-Phase, a programmable voltage source, an RL source, and a sensitive active and reactive load is connected with it. Table 2 below is presenting the parameters and the values of the testing system. Throughout this chapter, a convention of black, red, and blue is adapted for all three phases and with the same line design. The simulation was conducted with a 3-phase test system without a DVR connected with sensitive loads in MATLAB/Simulink and then a proposed DVR model with the power system in Simulink is presented in Figure 7. The simulations were conducted with a 3-phase test system with and without a DVR connected with sensitive loads in MATLAB/Simulink.

### A. INTERNAL CONTROL OF DVR

For control purposes, the different parameters and internal control of DVR, as shown in Figure 9, are simulated in the MATLAB/ Simulink. At the normal level of the supply voltage, to provide the lower number of losses in the conversion circuits, the DVR should be controlled in the transformer and the filtering circuits. When the voltage unbalance, or distorted voltage is detected in the system, then the required injected voltages are supplied to the test system through the installed DVR. Depend upon the voltage ( $V_{ref}$ ), the instantaneous value of the supply voltage ( $V_{supply}$ ), the whole process is accomplished by the feedback control technique. The reference voltages ( $V_{ref}$ ) are extracted by the control algorithm from the supply and the load voltages when the gate pulses provide the VSI to regulate the load voltage at the control algorithm's reference voltage. In this step, the detection of the voltage distortion, including voltage sag and voltage swell, can be done by calculating the problems among the dq-frame voltages of the load voltage ( $V_{Load}$ ) and the reference voltage ( $V_{ref}$ ). The abc frame is converted into the  $\alpha\beta$ -frames by connecting of the load voltage to a transformation block. The reference voltage will generate the gate pulses by equating the reference voltage ( $V_{ref}$ ) with that of the load voltage ( $V_{Load}$ ) in the case of any detection of the voltage swelling or sag and these pulses received by the VSI and by using the pulse width modulation (PWM), the

preferred voltage will be formed in a way to maintain the load voltage at the ( $V_{ref}$ ) or reference voltage, i.e., 330V.

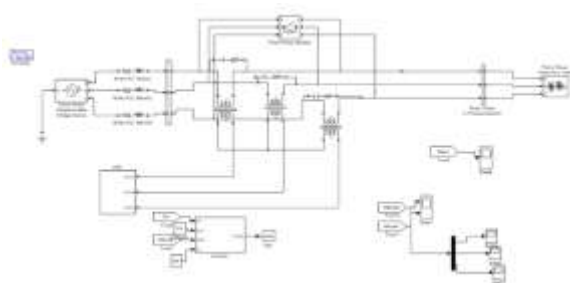

Fig9: Proposed Simulation Diagram

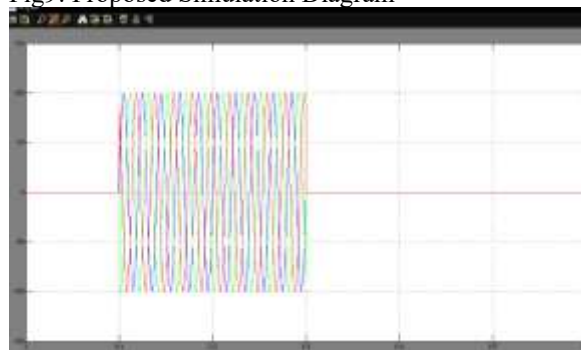

Fig10: Injected voltage ( $V_{inj}$ ) by DVR in all three phases



Fig11: load voltage and current

## VIII.CONCLUSION

DVR is proposed as the most noteworthy device to enhance the quality of power and proved to be a useful and well-performing device. Through the platform of MATLAB/ Simulink, a simulation of DVR with a power circuit is carried out by structure and modeling of the control circuit and power system with a sensitive load. The DVR is implemented with the test system and investigated with and without DVR. A programmable voltage source is used to supply a distorted voltage with first with 3rd harmonic content and then with 5 th harmonic insertion in the supply voltage. The proposed DVR based control strategy was effective in compensation of the distorted load voltage and maintained a better

steady and smooth voltage profile with very less harmonic content in it. To maintain the load voltage normal and steady at the optimal range, the correction of any problem in voltage supply is possible when the DVR injects the suitable voltage component into it. While maintaining the compensation of voltage profile, the THD was reduced to around 4%. Like for scenario 1, the observed THD with DVR case was 2.69%, 2.40%, and 2.69%, and for scenario 2, there were 3.74%, 4.04%, and 3.60% THD in the voltage profile. This improvement and reduction in the THD in load voltage explain the effectiveness of the DVR based control strategy used in this work. The application of control strategy based on soft computing like adaptive NeruoFuzz controllers for power quality improvement is a promising future perspective of this research. Authors have already implemented Type-2 NeuroFuzzy controls for enhancement of power system stability using STATCOM.

## REFERENCES

- [1] N. Khan, S. Dilshad, R. Khalid, A. R. Kalair, and N. Abas, "Review of energy storage and transportation of energy," *Energy Storage*, vol. 1, no. 3, Jun. 2019, doi: 10.1002/est.2.49.
- [2] M. A. Basit, S. Dilshad, R. Badar, and S. M. S. ur Rehman, "Limitations, challenges, and solution approaches in grid-connected renewable energy systems," *Int. J. Energy Res.*, vol. 44, no. 6, pp. 4132–4162, May 2020, doi: 10.1002/er.5033.
- [3] A. Kalair, N. Abas, A. R. Kalair, Z. Saleem, and N. Khan, "Review of harmonic analysis, modeling and mitigation techniques," *Renew. Sustain. Energy Rev.*, vol. 78, pp. 1152–1187, Oct. 2017, doi: 10.1016/j.rser.2017.04.121.
- [4] F. H. Gandoman, A. Ahmadi, A. M. Sharaf, P. Siano, J. Pou, B. Hredzak, and V. G. Agelidis, "Review of FACTS technologies and applications for power quality in smart grids with renewable energy systems," *Renew. Sustain. Energy Rev.*, vol. 82, pp. 502–514, Feb. 2018, doi: 10.1016/j.rser.2017.09.062.
- [5] A. M. Sharaf and A. A. Abdelsalamy, "A novel facts based dynamic voltage compensation scheme for smart electric grid stabilization and efficient utilization," in *Proc. 24th Can. Conf. Electr. Comput. Eng. (CCECE)*, May 2011, pp. 000042–000047, doi: 10.1109/CCECE.2011.6030405.
- [6] A. R. Kalair, N. Abas, A. Kalair, Q. U. Hasan, and N. Khan, "Impact of FACTS devices on transmission and distribution system," *J. Active Passiv. Electron. Devices*, vol. 14, no. 4, pp. 287–305, 2019.
- [7] M. Büyük, M. Inci, and M. Tümay, "Performance comparison of voltage sag/swell detection methods implemented in custom power

devices,” Rev. Roum. Sci. Techn.-Électrotechn. Énerg, vol. 62, no. 2, pp. 129–133, 2017.

[8] Y. W. Li and J. He, “Distribution system harmonic compensation methods: An overview of DG-interfacing inverters,” IEEE Ind. Electron. Mag., vol. 8, no. 4, pp. 18–31, Dec. 2014, doi: 10.1109/MIE.2013.2295421.

[9] N. G. Hingorani and L. Gyugyi, Understanding FACTS: Concepts and Technology of Flexible AC Transmission Systems. New York, NY, USA: Wiley, 2000.

[10] Y.-H. Song and A. Johns, Flexible ac Transmission Systems (FACTS), no. 30. Edison, NJ, USA: IET, 1999.