

IOT BASED LAMP ILLUMINATION CONTROL SYSTEM

Mrs. G. AMULYA PRIYANKA¹, V. SATYA SWARUPA RANI², P. SAI PRASANTH³

¹Assistant Professor, Dept. of ECE, PRAGATI ENGINEERING COLLEGE

²³UG Students, Dept. of ECE, PRAGATI ENGINEERING COLLEGE

ABSTRACT

A poor lighting system can cause eye-fatigue, glare, headache, short-sightedness and accident to the users. Therefore, appropriate lighting is very important in our working environment as well as our home. In daylight, natural light from sun helps to illuminate the indoor space. However, this natural light is very much dependent on the weather or windows position. If natural light is not enough to illuminate the interior, the light bulb is used to illuminate the space. However, current lighting system does not allow illumination control based on ambient light. The aim of this project is to provide appropriate lighting in the home based on human activities for the comfort of sight and eye health. This system consists of a dimmer circuit to control the artificial light illumination, a microcontroller (Arduino) with Wifi module, light sensors and an Android smart-phone. The system measures the intensity of ambient light and controls the artificial light to achieve used-defined lighting.

An app is developed using Android smart-phone for users to set their activity. This IoT-based system allows user to set the light intensity according to their choice. A prototype is developed and tested to verify the feasibility of the system. The results show the developed apps allow the user to set the activity and the brightness of the light bulb is in accordance with the specified activity

INTRODUCTION

In today's interconnected world, the Internet of Things (IoT) is revolutionizing how we interact with everyday objects, bringing unprecedented levels of convenience, efficiency, and control into our lives. One such application of IoT technology is the development of lamp illumination control systems. These systems leverage the power of the internet to remotely monitor and adjust the illumination levels of lamps in homes, offices, and public spaces.

At its core, an IoT-based lamp illumination control system consists of smart lamps equipped with sensors and connectivity modules, a central control hub, and a user interface accessible via smart phones, tablets, or computers. The sensors embedded within the lamps collect data on factors such as ambient light levels, occupancy, and user preferences. This data is then

transmitted to the central control hub, which processes it using advanced algorithms to determine the optimal illumination settings for each lamp in real-time.

One of the key advantages of an IoT-based lamp illumination control system is its ability to adapt to changing environmental conditions and user preferences automatically. For example, the system can dim the lights during daylight hours to conserve energy and reduce glare, or brighten them in response to occupancy or specific activities. Furthermore, users can remotely monitor and adjust the illumination levels of individual lamps or groups of lamps from anywhere with an internet connection, providing unprecedented flexibility and convenience.

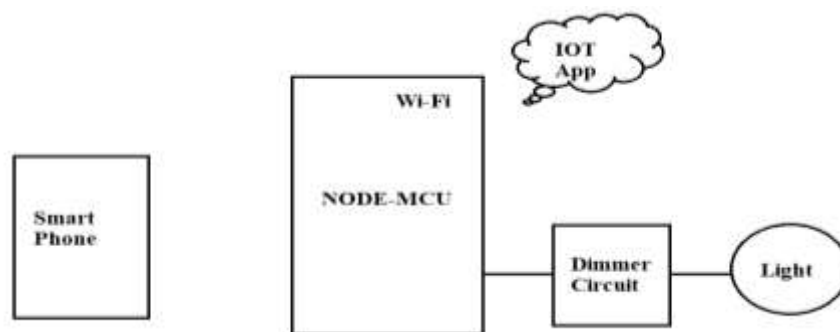

Figure.1 Block Diagram

LITERATURE SURVEY

1. Research about Ambient Light Control System Automatically Using PC-Based Microcontroller Arduino Uno. In this research, the system of a room light controller was carried out automatically; the design of the tool used the Arduino Uno as a microcontroller using the Arduino IDE program based on the C language. The similarity of this study with the one that the author is careful about is programming using Arduino IDE but for the microcontroller the author uses the Wemos D1 ESP2688.

2. "Bathroom Light Control Model Using Passive Infrared Receiver Sensor Based on Arduino Uno". In this study, the design of tools to control bathroom lights was carried out using the Arduino Uno as a microcontroller and a Passive Infrared Receiver (PIR) sensor as a motion detection sensor. The sensor is installed in the bathroom and points downward with a maximum distance of approximately 6 meters. It was explained that if someone enters the bathroom, the light will turn on with time (1 minute), and the light will turn off after the set time has elapsed without having to turn off the switch. The similarity between this study and the one that the author examined is the PIR sensor used to detect motion, but for the microcontroller the author uses the Wemos D1 ESP2688.

3. "Smart Home Application based on Android with Arduino Microcontroller". In this research, an application system with a smart home concept was designed; this system is used to control electronic equipment such as lights. The system uses the Arduino Uno as a microcontroller and uses a Bluetooth module as a communication medium with the microcontroller. It is explained that the maximum distance from this wireless connection module is approximately 10 meters. The light switch system in this tool is replaced by using a relay device and is controlled through a network-based microcontroller device so that it can be connected to a Smartphone that has a smart home controller application installed. The similarity of this study with that of the author is in terms of the control media using Android, but for the microcontroller the writer uses Wemos D1 ESP2688.

4. "Design of Product Monitoring System Using Internet of Things Technology for Smart Manufacturing". In this study discussed the design of a monitoring system on smart manufacturing based on internet of things technology. Smart technology is implemented on material scans automatically based on colour sensors, then from the material it will also be known that with these materials produce certain products and require any material. The similarity the system can running automatically based on sensors and system Internet of Things (IoT).

PROPOSED SYSTEM

The proposed system can remotely control the lamp's brightness using your IoT-based system. Keep in mind that safety precautions should be considered when working with AC voltages, and it's advisable to have a professional or someone experienced in electronics handle the hardware implementation.

User interacts with a mobile app or a web interface to send commands. Commands are sent to the ESP8266 through Wi-Fi. ESP8266 processes the command and adjusts the signal to the dimmer circuit. The dimmer circuit regulates the power supplied to the lamp, thus controlling the brightness simultaneously based on user selected mode.

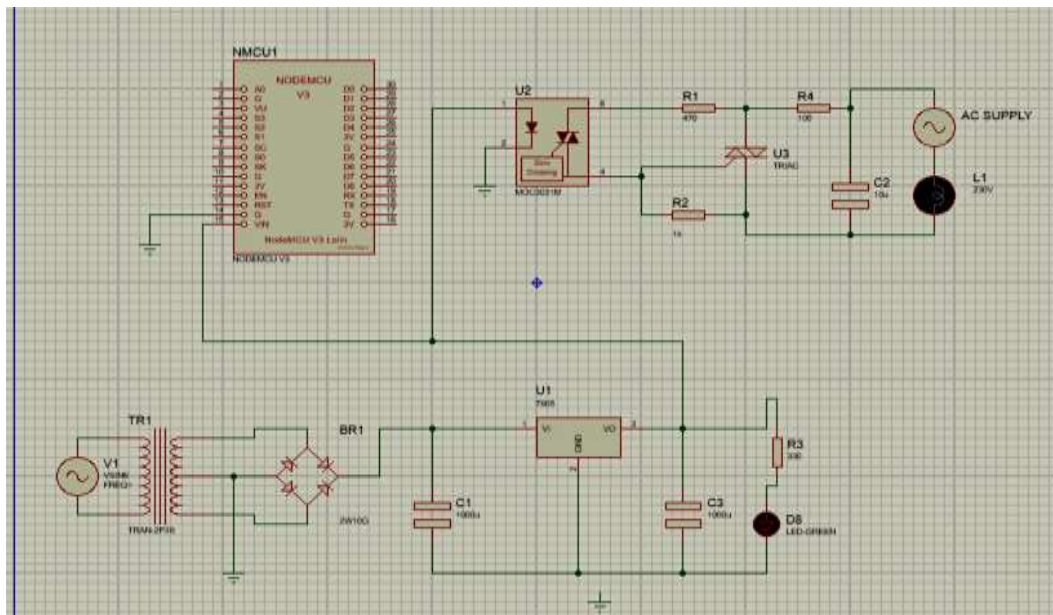

Figure.2 Schematic Diagram

RESULTS

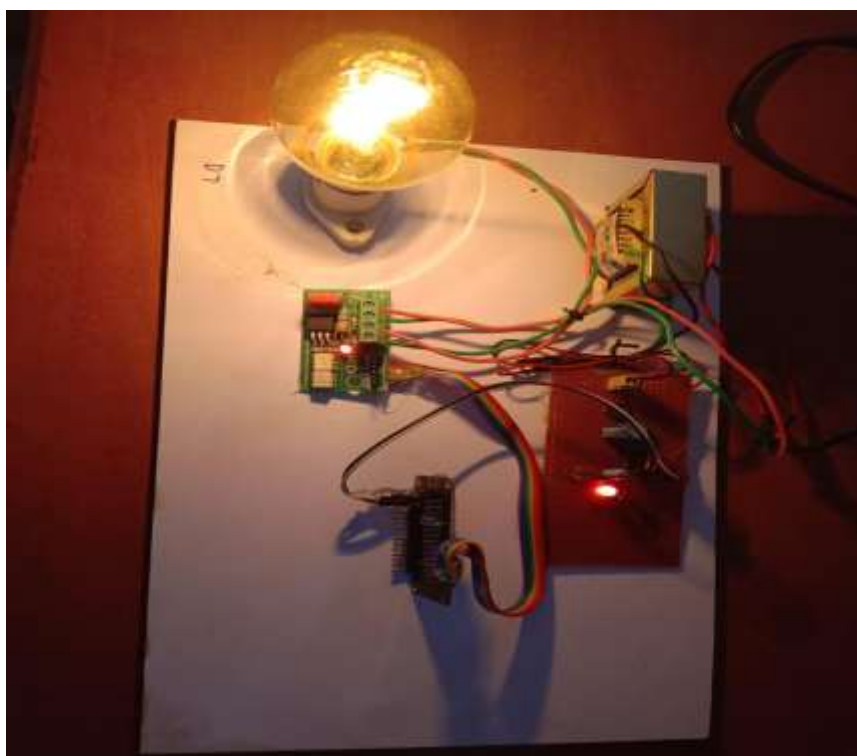

Figure.3 Study Mode

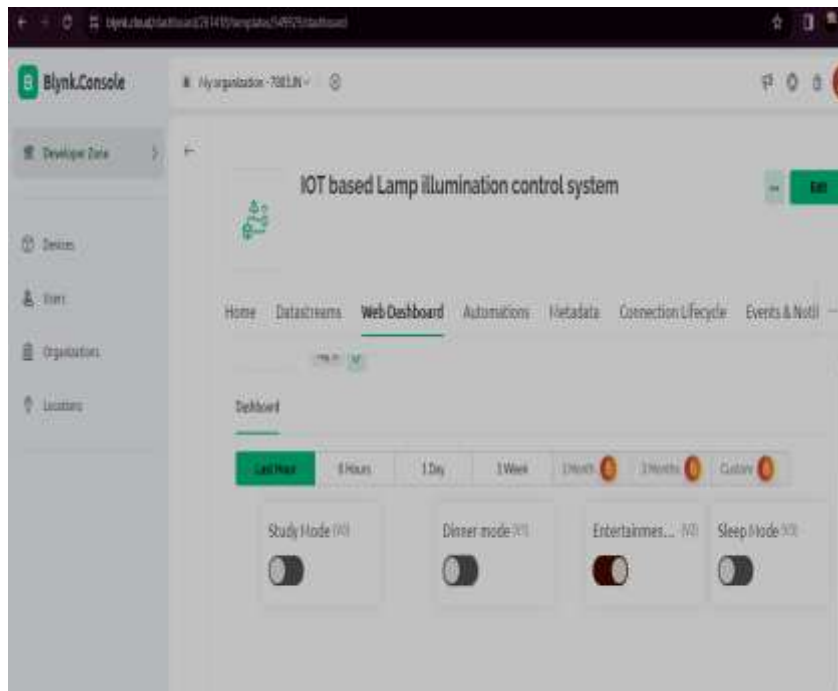

Figure.4 Blynk output

APPLICATIONS

Smart Home Lighting: Users can control the brightness and color of lamps in their homes remotely using a smartphone app. They can schedule lighting based on their preferences or occupancy, leading to energy savings and enhanced convenience.

Industrial Lighting Control: In industrial settings, IoT-controlled lamps can be used for efficient lighting management. Sensors can detect the presence of workers in specific areas and adjust the lighting intensity accordingly to optimize energy usage and provide adequate illumination for tasks.

Street Lighting: IoT-based lamp control systems can be implemented in smart cities to manage street lighting more efficiently. Lamps can be dimmed or brightened based on the time of day, weather conditions, or traffic density, leading to energy savings and improved safety.

Retail Lighting: Retail stores can use IoT-controlled lamps to create dynamic lighting scenes that enhance product displays and attract customers. Lighting can be adjusted based on factors like foot traffic, time of day, and promotions to create engaging shopping experiences.

Greenhouse Lighting: IoT-controlled lamps can be used in greenhouse environments to provide optimal lighting conditions for plant growth. Sensors can monitor environmental

factors like temperature and humidity and adjust the lighting accordingly to maximize crop yield and quality.

ADVANTAGES

Remote Access: Users can control the lamps from anywhere with an internet connection. This is convenient for adjusting lighting levels even when not at home or in the office.

Energy Efficiency: The system can optimize energy usage by adjusting brightness levels based on factors like time of day, occupancy, or natural light levels. This can lead to significant energy savings over time.

Automation: IoT-based systems can automate lighting adjustments based on pre-defined schedules or triggers, such as motion detection or ambient light sensors. This automation improves efficiency and can enhance security by simulating occupancy.

Data Insights: The system can collect data on usage patterns and energy consumption, providing valuable insights for further optimization and resource planning.

Integration: IoT-based lamp control systems can integrate with other smart home or building management systems, enabling seamless operation and coordination with other devices or processes

Scalability: The system can easily scale to accommodate additional lamps or expand to cover larger areas without significant infrastructure changes.

CONCLUSION

In conclusion, the IoT-based lamp illumination control system offers a myriad of advantages, revolutionizing traditional lighting management. By leveraging interconnected devices and sensors, it enables precise control over illumination levels, optimizing energy efficiency and reducing operational costs. The integration of smart features facilitates seamless automation, allowing users to remotely adjust lighting parameters based on preferences or environmental conditions. Moreover, the system's data-driven insights empower users with valuable analytics, fostering informed decision-making and enhancing overall user experience. With its scalability and adaptability, the IoT-based lamp illumination control system emerges as a pivotal solution in modern lighting infrastructure, promising not only enhanced convenience but also significant contributions to sustainability efforts and resource conservation.

FUTURE SCOPE

Energy Efficiency: Continued focus on energy efficiency will drive the development of smart algorithms and sensors that optimize lamp illumination based on factors such as occupancy, natural light levels, and user preferences. This will not only reduce energy consumption but also contribute to sustainability efforts.

Integration with Smart Cities: IoT lamp illumination control systems can be integrated into larger smart city initiatives. Streetlights equipped with sensors can adjust brightness based on real-time traffic conditions, pedestrian movement, or environmental factors like fog or rain, enhancing safety and reducing light pollution.

Health and Well-being: Research into the effects of artificial lighting on human health and circadian rhythms will lead to the development of smart lighting systems that adjust color temperature and intensity throughout the day to promote better sleep patterns and overall well-being.

Personalized Lighting Experience: IoT-enabled lamps can be integrated with personal devices and smart home assistants to provide a personalized lighting experience.

Data Analytics and Insights: The data collected from IoT lamp illumination control systems can be analyzed to gain insights into usage patterns, energy consumption, and environmental conditions. This data can inform decision-making processes for urban planning, energy management, and infrastructure maintenance.

REFERENCES

1. "Design of Smart LED Streetlight System Using IoT" by K. Sujatha, R. Vishnu Priya, M. Swathi, and M. Amrutha Published in: 2018 International Conference on Inventive Research in Computing Applications (ICIRCA) DOI: 10.1109/ICIRCA.2018.8473312
2. "IoT Based Intelligent Street Lighting System" by T. Maruthi, G. Rajesh, and G. Satyanarayana Published in: 2017 International Conference on Inventive Systems and Control (ICISC) DOI: 10.1109/ICISC.2017.8398791
3. "IoT Based Intelligent Street Lighting System for Smart City Applications" by Manikandan M., R. Jayaparvathy, and R. Hemalatha Published in: 2018 Second International Conference on Intelligent Computing and Control Systems (ICICCS) DOI: 10.1109/ICCONS.2018.8662900

4. "IoT Based Smart Street Light System" by Manisha Gokhale and Prachi Mujumdar
Published in: 2017 International Conference on Computing Methodologies and
Communication (ICCMC) DOI: 10.1109/ICCMC.2017.8282865

5. "An Intelligent and Efficient Light Control System Using IoT" by S. B. Patil and S. P. Awate
Published in: 2017 International Conference on Emerging Trends in Engineering, Technology
and Science (ICETETS) DOI: 10.1109/ICETETS.2017.8265502