

AUTOMATIC FIRE DETECTION, MONITORING AND CONTROLLING IN INDUSTRIES USING IOT

Mr. B. MANI BABU¹, T. YASASWINI², M. SUNEETHA³

¹Assistant Professor, Dept. of ECE, PRAGATI ENGINEERING COLLEGE

²³UG Students, Dept. of ECE, PRAGATI ENGINEERING COLLEGE

ABSTRACT

Security and automation is a prime concern in our day-to-day life. The approach to industrial automation and security system design is almost standardized nowadays. In this project, we have tried to increase these standards by combining new design techniques and developed low cost industrial automated security systems. Everyone wants to be as much as secure as possible. The design of project enables every user to use this wireless industrial fire and safety security system with fire sensors. The system is fully controlled by the Arduino based NodeMCU Single Board Computer. The NodeMCU will continuously monitor all the sensors and if it senses any fire then that information will be update in the IoT web server using in-built wifi module and DC water pump will ON to sprinkle the water and buzzer will activate as alarm to alert the employees.

INTRODUCTION

The advancement of technology has brought about numerous benefits to various industries, including enhanced safety measures. One such innovation is the use of Internet of Things (IoT) technology for automatic fire detection, monitoring, and controlling in industries. In industrial settings where fire hazards are prevalent, such as manufacturing plants, warehouses, and chemical facilities, the timely detection and management of fires are crucial to preventing catastrophic accidents, minimizing property damage, and ensuring the safety of personnel.

Traditional fire detection systems rely on manual intervention or basic automated alarms, which may not always provide accurate and timely information. Moreover, in large industrial complexes, it can be challenging to monitor and control fire hazards effectively in real-time. This is where IoT-based solutions come into play, offering a more efficient and proactive approach to fire safety management.

The project on automatic fire detection, monitoring, and controlling in industries using IoT aims to leverage the power of interconnected devices, sensors, and data analytics to create a robust fire safety system. By deploying a network of IoT-enabled sensors strategically throughout the industrial facility, it becomes possible to continuously monitor various parameters, such as

temperature, smoke levels, and gas concentrations, in different areas.

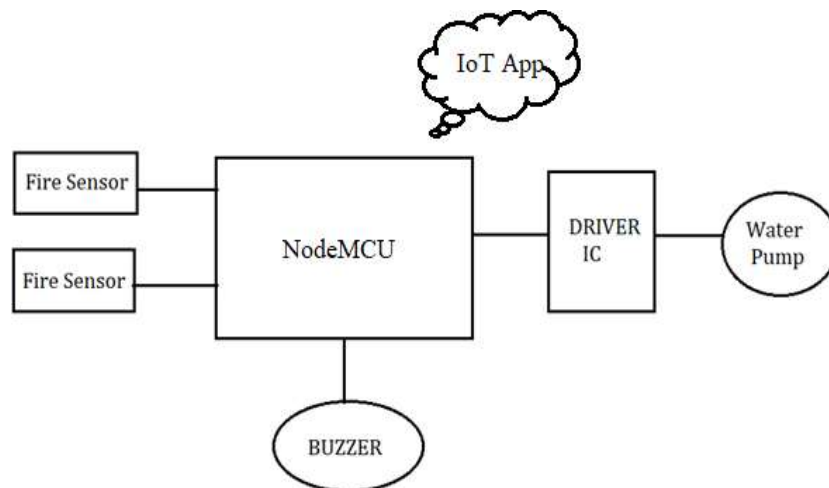

Figure.1 Block Diagram

OBJECTIVE OF THE PROJECT

The primary objective of the project on automatic fire detection, monitoring, and controlling in industries using IoT is to enhance fire safety measures in industrial environments.

Specifically, the project aims to achieve the following objectives:

Real-time Detection: Implement IoT-based sensors and devices to continuously monitor various parameters, such as temperature, smoke levels, and gas concentrations, in industrial facilities. The objective is to detect abnormal patterns or anomalies indicative of fire or potential fire hazards promptly.

Timely Alerting: Develop a system capable of triggering immediate alerts to designated personnel, emergency response teams, and automated firefighting systems upon detecting fire-related events. The goal is to ensure timely notification and response to mitigate the risk of fire.

Data Visualization and Analytics: Enable stakeholders to access real-time data visualization and analytics tools to make informed decisions and take proactive actions in managing fire hazards. The objective is to provide insights into fire risk levels, trends, and potential mitigation strategies.

Integration with Control Systems: Integrate the IoT-based fire safety system with existing industrial automation and control systems to facilitate coordinated responses during emergency situations. The objective is to automate actions such as equipment shutdown, fire suppression system activation, and evacuation procedures based on predefined protocols and safety guidelines.

Enhance Overall Safety: Ultimately, the overarching objective of the project is to enhance overall fire safety measures in industrial environments by leveraging IoT technology to detect,

monitor, and control fire hazards effectively. The goal is to minimize the risk of catastrophic accidents, property damage, and human casualties associated with industrial fires.

LITERATURE SURVEY

“Advancements in Automatic Fire Detection”

The concept of automatic fire detection systems has gained significant attention in recent years due to reduce costs and improve safety. Several studies have proposed various approaches to automatic fire detection systems using advanced technologies such as the IoT, artificial intelligence (AI), power electronics, wireless sensor networks. The future of fire safety is looking brighter with the advancements in fire alarm technology. With new innovations in sensors, wireless systems, and artificial intelligence, fire alarms can now detect fires more accurately and quickly. This has the potential to save lives and minimize damage in the event of a fire.

“Remote monitoring and control”

Remote monitoring and control capabilities have transformed the way fire alarm systems are managed. With remote access to fire alarm systems from a central location, monitoring and managing these systems has never been easier. This is particularly beneficial for large or complex buildings that have multiple fire alarm systems spread across different locations.

“Cloud-based fire alarm systems”

Cloud technology has revolutionized the way fire alarm systems operate. Cloud-based fire alarm systems store data in the cloud, eliminating the need for physical servers. This enables real-time monitoring and analysis of fire alarm data from anywhere in the world. By harnessing the power of the cloud, building owners and fire safety professionals can access crucial information instantly, allowing for swift decision-making and response.

“Internet of Things (IoT) fire alarm systems”

IoT fire alarm systems have emerged as a game-changer in the realm of fire safety. By utilising sensors, communication technology, and cloud-based computing, these systems provide real-time monitoring and analysis of fire alarm data.

PROPOSED SYSTEM

The integration of IoT technology into fire detection systems promises significant advancements in functionality, reliability, and efficiency. IoT-enabled systems leverage interconnected sensors, data analytics, and cloud computing to enhance the capabilities of traditional fire detection systems.

One of the key advantages of IoT-enabled fire detection systems is their connectivity. By

leveraging wireless communication protocols such as Wi-Fi or Bluetooth, these systems enable real-time monitoring and control from any location. Building managers can access system data remotely, receive instant alerts in case of fire incidents, and initiate appropriate response actions promptly.

Moreover, IoT-enabled systems offer enhanced intelligence and analytics capabilities. By collecting and analyzing data from multiple sensors in real-time, these systems can distinguish between genuine fire events and false alarms more accurately.

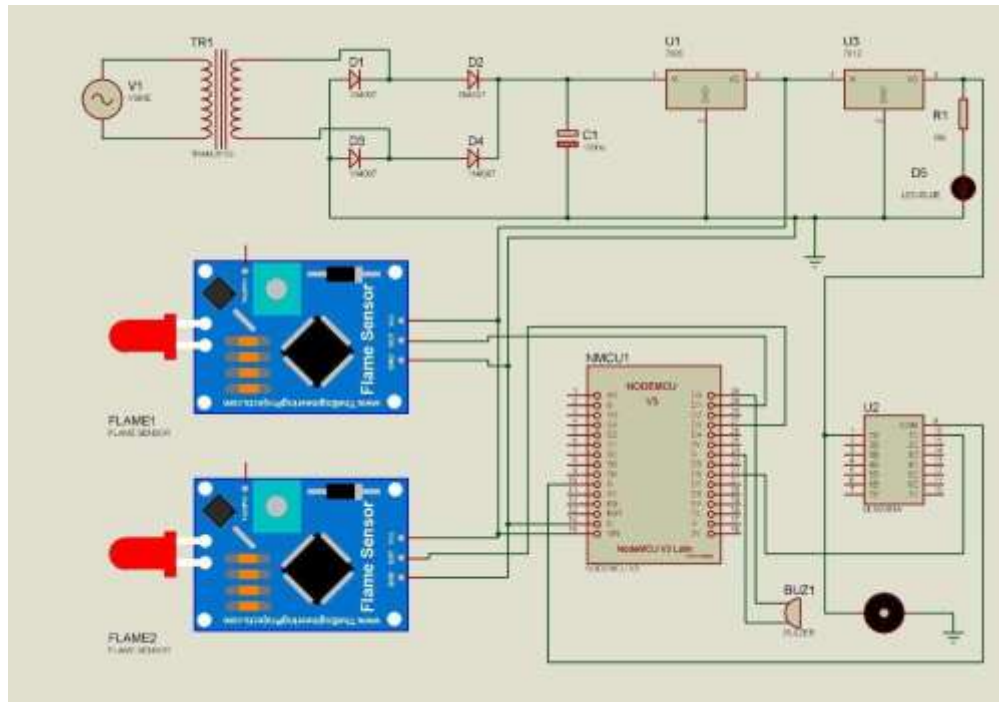

Figure.2 Schematic Diagram

RESULTS



Figure.3 Working Kit

figure.4 No fire on blynk

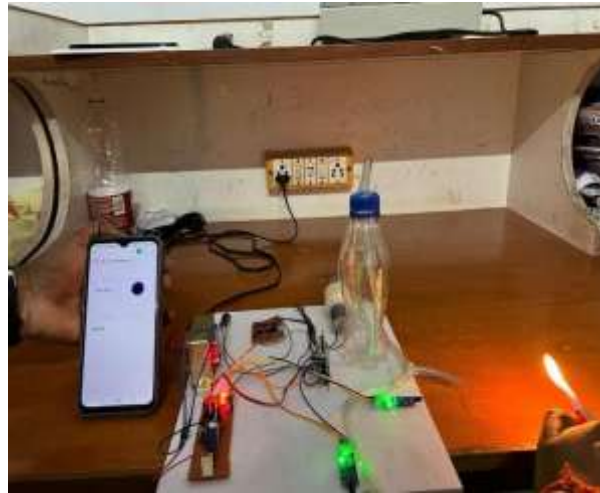

Figure.5 Fire at 1st IR sensor

ADVANTAGES

Real-time Monitoring: IoT-enabled fire detection systems provide real-time monitoring of environmental conditions, including temperature, smoke levels, and other relevant parameters. This continuous monitoring ensures early detection of fire incidents, allowing for prompt response and mitigation measures.

Remote Accessibility: With IoT technology, fire detection systems can be accessed and managed remotely via web-based interfaces or mobile applications. Building managers, security personnel, and emergency responders can monitor the system status, receive alerts, and take necessary actions from anywhere with an internet connection, enhancing responsiveness and situational awareness.

Reduced Maintenance Costs: IoT technology facilitates remote diagnostics and predictive maintenance capabilities, allowing for proactive monitoring of system health and early detection of potential issues. By identifying maintenance needs before they lead to system failures, IoT-enabled fire detection systems help reduce downtime, maintenance costs, and ensure continuous operation.

CONCLUSION

The adoption of IoT technology in industrial fire safety systems marks a significant advancement, offering a comprehensive approach to fire detection, monitoring, and controlling. By leveraging interconnected devices and data-driven insights, industries can enhance their ability to prevent, detect, and respond to fire incidents effectively. The integration of IoT brings about several key benefits:

Real-time Monitoring: IoT-enabled sensors provide continuous monitoring of environmental conditions, allowing for early detection of fire hazards. This real-time monitoring capability ensures prompt response to potential threats, minimizing the risk of fire-related damages and injuries.

Data-driven Insights: IoT systems generate vast amounts of data, which can be analyzed to identify patterns, trends, and anomalies. By harnessing data analytics techniques, industries can gain valuable insights into fire risk factors, enabling proactive measures to mitigate risks and enhance safety protocols.

Remote Accessibility: IoT platforms enable remote access to fire safety systems via mobile devices or web interfaces. This remote accessibility empowers stakeholders to monitor and manage fire safety operations from anywhere, facilitating swift decision-making and response coordination, particularly in large-scale industrial facilities or distributed environments.

Automation and Integration: IoT facilitates automation of fire detection and suppression processes, streamlining operations and reducing reliance on manual intervention. Moreover, Automatic Fire Detection, Monitoring & Controlling In Industry Using IO integration with existing industrial systems, such as building management systems (BMS) and security systems, enhances overall operational efficiency and coordination of emergency responses.

FUTURE SCOPE

Advanced Sensor Technologies: Continued advancements in sensor technologies will lead to the development of more sophisticated and reliable fire detection sensors. Sensors capable of detecting various fire-related parameters, such as temperature, smoke density, and gas emissions, with higher accuracy and sensitivity will further enhance early warning capabilities.

Artificial Intelligence and Machine Learning: Integration of artificial intelligence (AI) and machine learning (ML) algorithms with IoT systems will enable predictive analytics and proactive risk management. AI-driven algorithms can analyze historical data, identify emerging fire patterns, and predict potential fire incidents, allowing for preemptive measures to be taken to mitigate risks.

Edge Computing and Fog Computing: The adoption of edge computing and fog computing technologies will enable data processing and analysis to be performed closer to the source of data generation. This decentralized approach reduces latency, improves response times, and enhances the scalability of IoT fire safety systems, particularly in environments with limited network bandwidth or connectivity.

Smart Building Integration: Integration of IoT fire safety systems with smart building technologies will enable more holistic and coordinated fire safety management. By leveraging interconnected building systems, such as lighting, ventilation, and access control, industries can optimize emergency response strategies and minimize the impact of fire incidents on occupants and assets.

Cybersecurity and Data Privacy: As IoT adoption continues to proliferate, ensuring robust cybersecurity measures and protecting sensitive data will be paramount. Industries must prioritize cybersecurity protocols to safeguard IoT-enabled fire safety systems from cyber threats, unauthorized access, and data breaches, thereby maintaining the integrity and reliability of critical safety infrastructure.

REFERENCES

1. Raja, M. (2018). IoT-based Fire Detection and Monitoring System for Industries. *International Journal of Computer Applications*, 180(33), 9-12.
2. Vinothini, S., & Vimala, S. (2019). IoT-based Fire Detection and Controlling System for Industrial Safety. *2019 International Conference on Communication and Signal Processing (ICCSP)*, 1543-1547.
3. Ponmalar, P., & Suganthi, S. (2020). IoT-based Industrial Fire Detection and Controlling System. *2020 11th International Conference on Computing, Communication and Networking Technologies (ICCCNT)*, 1-6.
4. Mukundan, R., & Kumar, R. (2017). Smart Fire Detection and Control System Using IoT. *2017 International Conference on Wireless Communications, Signal Processing and Networking (WiSPNET)*, 1468-1471.
5. Gupta, A., Mittal, A., & Bhatia, A. (2020). IoT-based Industrial Fire Detection and Controlling System. *2020 2nd International Conference on Advances in Computing, Communication Control and Networking (ICACCCN)*, 467-472
6. Al-Kashoash, H. A., & Alyasseri, Z. A. (2021). A Review of IoT-based Fire Detection Systems. *International Journal of Electrical and Computer Engineering (IJECE)*, 11(1), 936-942.
7. Reddy, K. B., & Rao, G. K. (2018). Smart Fire Detection and Control System Using IoT. *International Journal of Engineering Research in Electronics and Communication Engineering (IJERECE)*, 5(6), 30-33.
8. Peng, S., Chen, J., & Luo, C. (2019). Design of IoT-based Fire Alarm System for Industrial Safety. *2019 2nd International Conference on Information Science and Systems (ICISS)*, 297-301.

9. El-Aziz, M. A., Hafez, A. E., & El-Gayar, H. (2019). IoT-based Fire Detection and Control System for Industrial Applications. 2019 IEEE International Conference on Smart Internet of Things (SmartIoT), 135-140.