

## SMART STREETLIGHT CONTROLLING SYSTEM WITH LDR AND IR SENSOR USING ARDUINO UNO

Dr. A. SRINIVAS<sup>1</sup>, D. POOJITHA<sup>2</sup>, V.K.P. SWETHA<sup>3</sup>

<sup>1</sup>Associate Professor, DEPT.OF ECE, PRAGATI ENGINEERING COLLEGE

<sup>23</sup>UG Students, DEPT. OF ECE, PRAGATI ENGINEERING COLLEGE

### ABSTRACT

Smart Street light is an automated system which automates the street. The main aim of Smart Street light is to reduce the power consumption when there are no vehicle movements on the road. The Smart Street light will glow with high intensity when there are vehicles on the road otherwise the lights will have less brightness than when the lights are completely turned on. This means when there is no vehicle around, the intensity of light will be around 30%. With advancement of technology, things are becoming simpler and easier for everyone in the world today. Automation is the use of control systems and information technologies to reduce the need for human work in the production of goods and services. In the scope of industrialization, automation is a step beyond mechanization, whereas mechanization provided human operators with machinery to assist the users with the muscular requirements of work, automation greatly decreases the need for human sensory and mental requirements as well. Automation plays an increasingly important role in the world economy and in daily experience. Automatic systems are being preferred over manual system. The research work shows automatic control of streetlights as a result of which power is saved to an extent. The Smart Street light provides a solution for energy saving which is achieved by sensing an approaching vehicle using the IR sensors and then switching ON a block of street lights ahead of the vehicle with high intensity. As the vehicle passes by, the trailing lights reduce its brightness. Thus, we save a lot of energy. So, when there are no vehicles on the highway, then all the lights will reduce its brightness intensity to 30%.

### INTRODUCTION

In a world increasingly focused on sustainability and resource efficiency, the concept of the Smart Streetlight emerges as a beacon of innovation. This automated system transcends traditional street lighting by dynamically adjusting its intensity based on real-time traffic

conditions, aiming to drastically reduce power consumption while enhancing safety and security.

The driving force behind this advancement lies in the power of automation. As technology relentlessly progresses, its tendrils reach into every aspect of our lives, simplifying processes and revolutionizing industries. In the context of industrialization, automation represents a significant leap beyond mere mechanization. While mechanization provided tools to augment human physical capabilities, automation goes further, minimizing the need for human intervention in both sensory and cognitive tasks. This transformative technology has become deeply embedded in the global economy, impacting everything from manufacturing to healthcare, and its influence extends to our daily experiences as well.

The preference for automated systems over manual ones is undeniable. This shift is fueled by the undeniable benefits automation offers, including increased efficiency, reduced costs, and enhanced accuracy. In the realm of street lighting, research has conclusively demonstrated the substantial energy savings achievable through automated control.

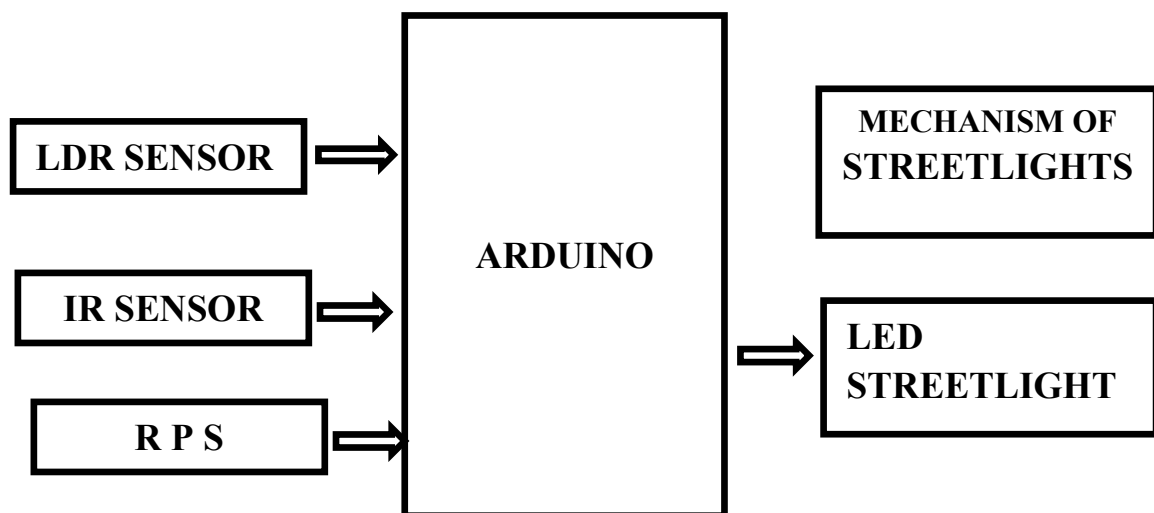

Figure.1 Block Diagram

**OBJECTIVE OF THE PROJECT**

To develop and implement a smart streetlight controlling system using Arduino Uno, IR sensors, and LDRs, aiming to:

- Reduce energy consumption by dynamically adjusting light intensity based on real-time traffic conditions.
- Enhance safety by ensuring sufficient illumination for approaching vehicles.

- Demonstrate the effectiveness of automation in optimizing street lighting infrastructure.

## LITERATURE SURVEY

### 1. Advancements in Smart Street Lighting Systems

The concept of smart street lighting systems has gained significant attention in recent years due to their potential to enhance energy efficiency, reduce costs, and improve public safety. Several studies have proposed various approaches to smart street lighting systems using advanced technologies such as the IoT, artificial intelligence (AI), power electronics, wireless sensor networks. The system was able to adjust the brightness of the street lights based on the ambient light level, as well as detect and report any faults in the system. Another study by A. Imran et al. (2019) proposed a smart street lighting system that utilized a combination of IoT, cloud computing, and big data analytics.

### 2. Revolutionizing Urban Illumination

It is stated that the current traditional street lighting systems are inefficient, as they operate on fixed schedules and are not adaptive to real-time changes in traffic or weather conditions. The literature survey highlights that smart street lighting systems can improve energy efficiency, reduce maintenance costs, and enhance public safety. They discuss various approaches, such as using sensors and wireless communication technologies to monitor and control the street lighting system. They also highlight some of the challenges associated with implementing such systems, including the need for reliable and secure communication protocols and the high cost of installation and maintenance.

### 3. Optimizing Urban Illumination

They discuss various approaches, such as using sensors, wireless communication, and machine learning algorithms, to monitor and control the street lighting system. They also highlight some of the challenges associated with implementing such systems, including the need for reliable and secure communication protocols and the high cost of installation and maintenance. These also include various research on different sensor technologies used in smart street lighting systems, such as IR sensors, PIR sensors, and ultrasonic sensors. The survey also examines different control strategies for these systems, including manual control, time-based control, and adaptive control. Additionally, the literature survey discusses the benefits of smart street lighting systems, such as energy savings, improved safety, and reduced maintenance costs. The survey also explores the challenges associated with implementing these systems, including the

initial cost of installation and the need for technical expertise to maintain and operate the system.

#### **4. Sensor Technologies And Benefits In Smart Street Lighting System**

The survey examines different sensor technologies used in smart street lighting systems, including IR sensors, PIR sensors, and ultrasonic sensors. Additionally, the literature survey discusses the benefits of smart street lighting systems, such as energy savings, improved safety, and reduced maintenance costs. The survey also explores the challenges associated with implementing these systems, such as the need for technical expertise and the initial cost of installation. Furthermore, the literature survey highlights the importance of using Lab.

#### **PROPOSED SYSTEM**

A smart streetlight controlling system utilizing LDR and IR sensors with Arduino seamlessly manages streetlight operation based on ambient light conditions and detected motion. The LDR sensor continuously monitors light levels, discerning between day and night, while the IR sensor detects nearby motion. The Arduino, acting as the system's brain, processes inputs from both sensors and makes decisions accordingly. If the LDR indicates low light levels during nighttime and the IR sensor detects motion, the Arduino triggers the relay module to turn on the streetlight.

Conversely, during daylight or when no motion is detected, the Arduino turns off the streetlight to conserve energy. This autonomous and energy-efficient system not only ensures optimal lighting conditions but also contributes to cost savings and sustainability in urban lighting infrastructure. Calibration precision, fail-safe mechanisms, and regular maintenance are essential considerations for the reliable operation of this smart streetlight solution.

Also the mechanism that takes place during the night also helps to conserve the energy by dimming the light by a specific percentage and when the motion is detected the lights glow with 100% brightness. This helps to conserve more power than the existing streetlight system.

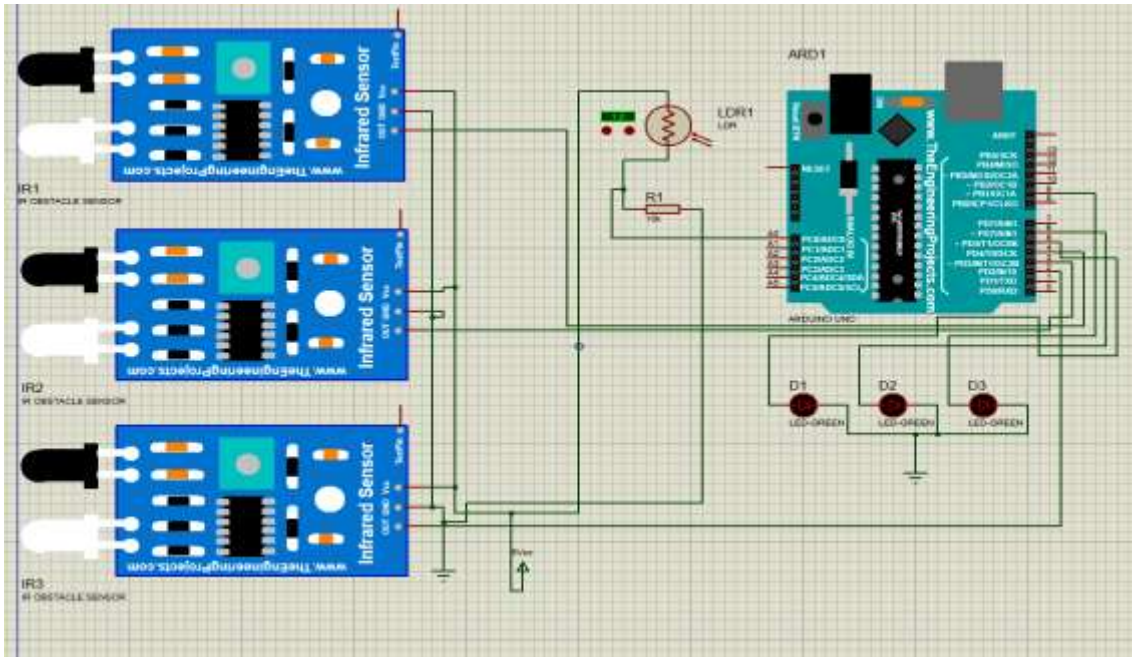

Figure.2 Schematic Diagram

### RESULTS

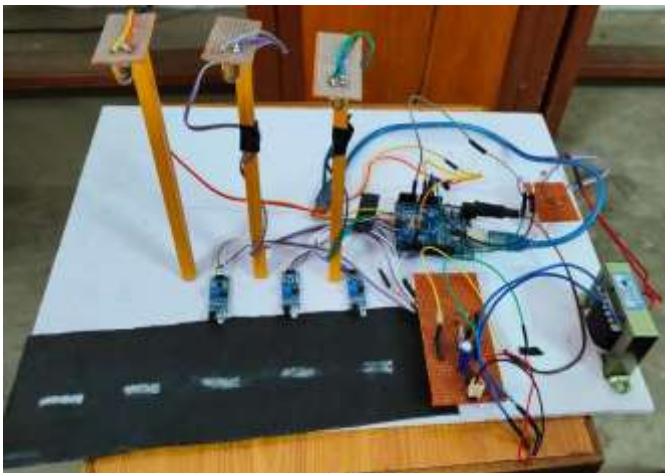

Figure.3 Working kit

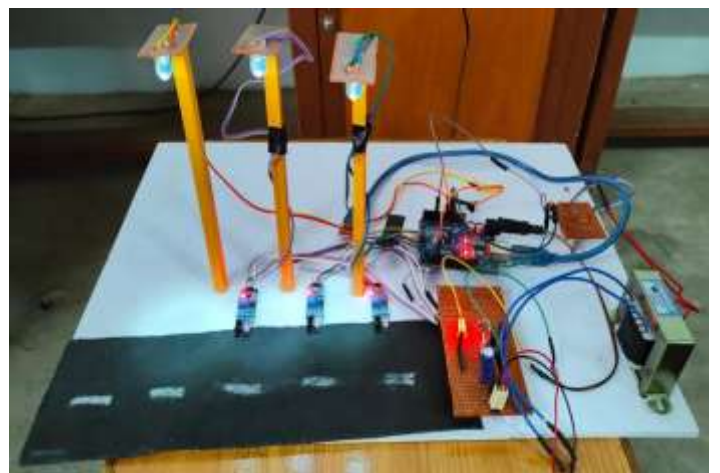

Figure.4 No vehicle condition(20% light)

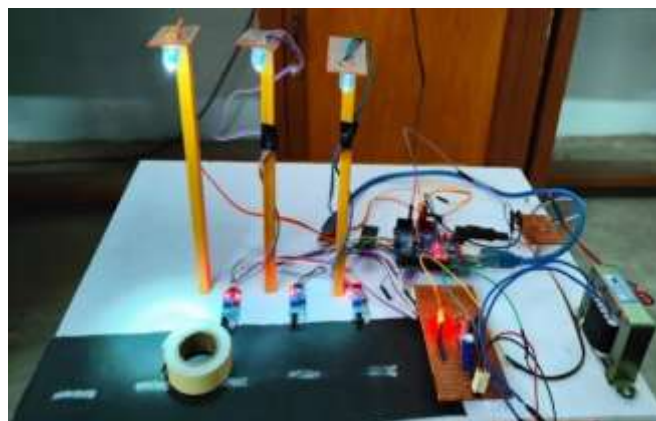

Figure.5 Vehicle @ 1<sup>st</sup> IR Sensor(100% light)

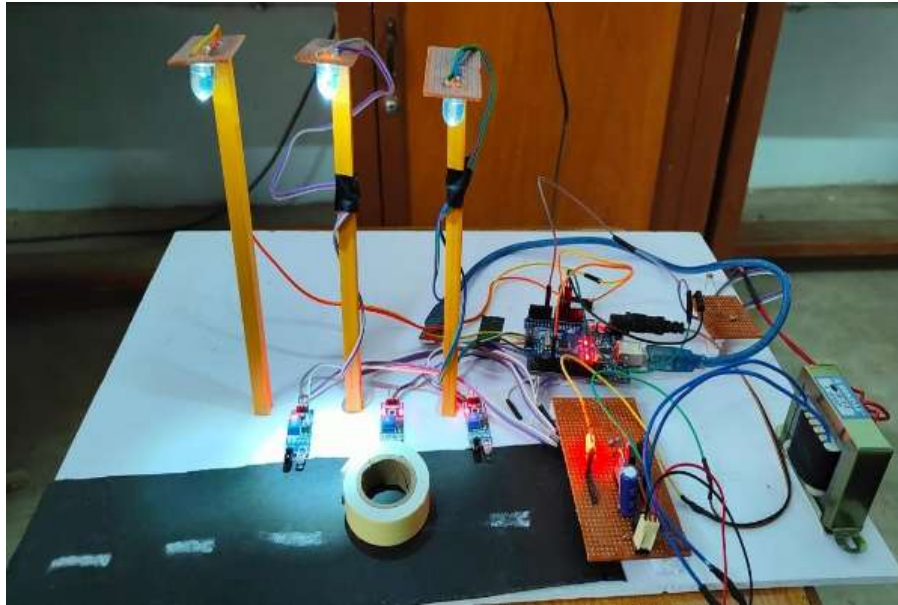

Figure.6 Vehicle @ 2<sup>nd</sup> IR Sensor (LED 100% light)

### ADVANTAGES

- ✓ Automatic Switching of Street Lights.
- ✓ Maintenance Cost Reduction.
- ✓ Reduction in CO2 emission.
- ✓ Energy saving.
- ✓ Reduction of manpower.

### CONCLUSION

The constructing and testing path of the smart street light controlling system has been a rewarding experience, filled with challenges, discoveries, and ultimately, successful implementation. This project culminated in a system that effectively adapts LED brightness based on ambient light and detected movement, demonstrating its potential to contribute to energy efficiency and improved night visibility in public spaces.

### Reflecting on our Achievements:

- **Functionality Confirmed:** The system successfully fulfilled its core objectives. IR sensors accurately detected movement in their respective zones, triggering the corresponding LEDs to illuminate the area. Moreover, the LEDs gracefully adjusted their brightness based on LDR readings, ensuring efficient light use under varying ambient conditions.
- **Performance Evaluation:** Testing revealed promising results. The response time for movement detection and LED activation was commendable, ensuring a prompt reaction to

changes in the environment. The system accurately differentiated between movement and environmental noise, demonstrating reliable sensor performance.

- **Beyond Basic Functionality:** The project explored potential applications beyond simple on/off switching. By implementing PWM control, the system achieved smooth LED brightness transitions, enhancing the user experience and potentially extending LED lifespan. Furthermore, incorporating an LDR allowed for dynamic adjustments based on ambient light, leading to a more natural and comfortable illumination level.

### FUTURE SCOPE

- **Enhanced Detection Range:** Utilizing sensors with a wider detection range could cover larger areas, making the system more suitable for diverse applications.

- **Environmental Resilience:** Addressing the impact of direct sunlight on IR sensor readings could involve shielding or strategic sensor placement, ensuring reliable performance in varied environmental conditions.

- **Advanced Code Optimization:** Implementing a debounce timer could further reduce false positives triggered by sensor noise, enhancing overall system accuracy.

### REFERENCES

1. International Journal of Innovative Research in Computer and Communication Engineering (An ISO 3297: 2007 Certified Organization) Website: www.ijircce.com Vol. 5, Issue 3, March 2017 Smart Street Light Using Arduino Uno Microcontroller
2. S. Suganya, R. Sinduja, T. Sowmiya& S. Senthilkumar, Street light glow on detecting vehicle movement using sensor
3. K.Santha Sheela,S.Padmadevi, Survey on Street Lighting System Based On Vehicle Movements
4. Srikanth M, Sudhakar K N,ZigBee Based Remote Control Automatic Street Light System
5. M.Abhishek, Syed ajram shah, K.Chetan, K,Arun Kumar, Design and implementation of traffic flow based street light control system with effective utilization of solar energy, International journal of Science Engineering and Advance Technology, IJSEAT, Vol