

# IOT BASED GREENHOUSE MONITORING AND CONTROLLING SYSTEM

Mrs. D. V.V. LAKSHMI<sup>1</sup>, M. SATYA CHINMAYI<sup>2</sup>, M. ANUSHA<sup>3</sup>

<sup>1</sup>Assistant Professor, Dept. of ECE, PRAGATI ENGINEERING COLLEGE

<sup>2,3</sup>UG Students, Dept. of ECE, PRAGATI ENGINEERING COLLEGE

## ABSTRACT

The Aim of this project to design a Green house monitoring and weather station monitoring over IoT System, which can be monitor A greenhouse is a structure that is built of walls and a transparent roof and is designed to maintain regulated climatic conditions. These structures are used for the cultivation of plants, fruits, and vegetables which require a particular level of sunlight, temperature, humidity. The project uses sensors to detect the Soil moisture, Temperature, Light, and Humidity in the Greenhouse and weather monitoring. Soil moisture sensor detects condition of soil whether dry / wet. If the soil of the plant is dry, user can ON the motor pump according to the requirement from web server. The water pump is OFF once the soil becomes wet. Temperature Sensor is used to detect the temperature and humidity readings from the DHT sensor is sent to the microcontroller. The microcontroller is connected to DC Fan switches accordingly. If the temperature is above the threshold value, the microcontroller would send signals to turn ON the Fan. Light Sensor is used to detect the amount of sunlight inside the greenhouse. Reading from the sensor is sent to the microcontroller. If the Sunlight is above the threshold value, the microcontroller would send signals to turn ON the relay. This now processes this data and keeps on transmitting it to the online web server over a WiFi connection. This data is live updated to be viewed on the online server system.

## INTRODUCTION

The Aim of this project to design a Green house monitoring and weather station monitoring over IoT System, which can be monitor A greenhouse is a structure that is built of walls and a transparent roof and is designed to maintain regulated climatic conditions. These structures are used for the cultivation of plants, fruits, and vegetables which require a particular level of sunlight, temperature, humidity. The project uses sensors to detect the Soil moisture,

Temperature, Light, and Humidity in the Greenhouse and weather monitoring. Soil moisture sensor detects condition of soil whether dry / wet. If the soil of the plant is dry, user can ON the motor pump according to the requirement from web server. The water pump is OFF once the soil becomes wet. Temperature Sensor is used to detect the temperature and humidity readings from the DHT sensor is sent to the micro-controller. The micro-controller is connected to DC Fan switches accordingly. If the temperature is above the threshold value, the microcontroller would send signals to turn ON the Fan. Light Sensor is used to detect the amount of sunlight inside the greenhouse. Reading from the sensor is sent to the microcontroller. If the Sunlight is above the threshold value, the microcontroller would send signals to turn ON the relay. This now processes this data and keeps on transmitting it to the online web server over a WiFi connection. This data is live updated to be viewed on the online server system.

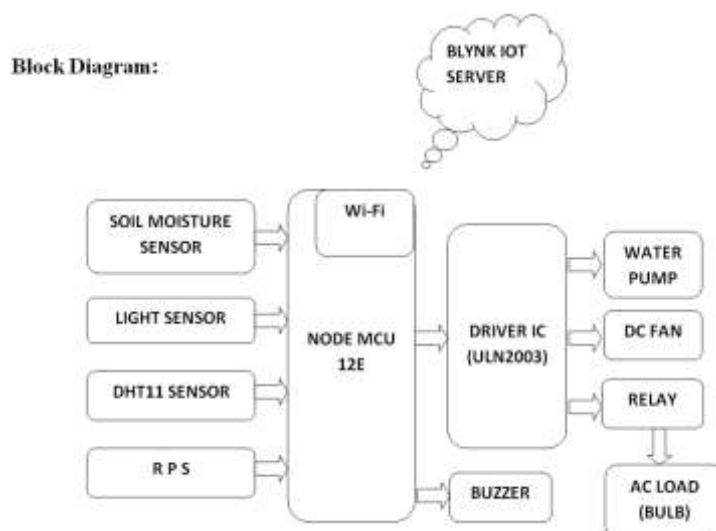

Figure.1 Block Diagram

## LITERATURE SURVEY

### Introduction to IoT in Greenhouse Monitoring and Control:

Start with an overview of the role of IoT in greenhouse management, emphasizing the importance of real-time monitoring and automation for optimizing crop yield, resource usage, and environmental conditions.

Explore literature discussing the benefits of IoT-enabled greenhouse systems, such as increased productivity, reduced resource consumption, and improved crop quality.

**Design and Architecture of IoT-Based Greenhouse Systems:**

Investigate research papers and articles that discuss the design principles and architecture of IoT-based greenhouse monitoring and controlling systems.

Look for studies that describe the integration of sensors, actuators, microcontrollers, communication protocols, and cloud platforms to enable data collection, analysis, and control of greenhouse environments.

**Sensor Technologies for Environmental Monitoring:**

Review literature on sensor technologies used in IoT-based greenhouse systems for environmental monitoring.

Explore studies that discuss the deployment of sensors such as temperature sensors, humidity sensors, soil moisture sensors, light sensors, CO<sub>2</sub> sensors, and pH sensors to monitor key parameters affecting plant growth.

**Data Collection and Transmission:**

Examine research papers and articles that discuss data collection and transmission mechanisms in IoT-based greenhouse systems.

Look for studies that describe how sensor data is collected, processed, and transmitted to cloud servers or edge devices using wireless communication protocols such as Wi-Fi, Zigbee, LoRaWAN, or cellular networks.

**Cloud Platforms for Data Storage and Analysis:**

Investigate literature on cloud platforms used for data storage and analysis in IoT-based greenhouse systems.

Explore studies that discuss the integration of cloud services such as AWS IoT, Microsoft Azure IoT, Google Cloud IoT, or IBM Watson IoT for storing sensor data, running analytics algorithms, and generating insights.

**PROPOSED SYSTEM**

The project uses sensors to detect the Soil moisture, Temperature, Light, and Humidity in the Greenhouse and weather monitoring. Soil moisture sensor detects condition of soil whether dry / wet. If the soil of the plant is dry, user can ON the motor pump according to the requirement from web server. The water pump is OFF once the soil becomes wet. Temperature Sensor is used to detect the temperature and humidity readings from the DHT sensor is sent to the micro-controller. The micro-controller is connected to DC Fan switches accordingly. If the temperature is above the threshold value, the microcontroller would send signals to turn ON the Fan. Light Sensor is used to detect the amount of sunlight inside the greenhouse. Reading from the sensor is sent to the microcontroller. If the Sunlight is above the threshold value, the microcontroller would send signals to turn ON the relay.

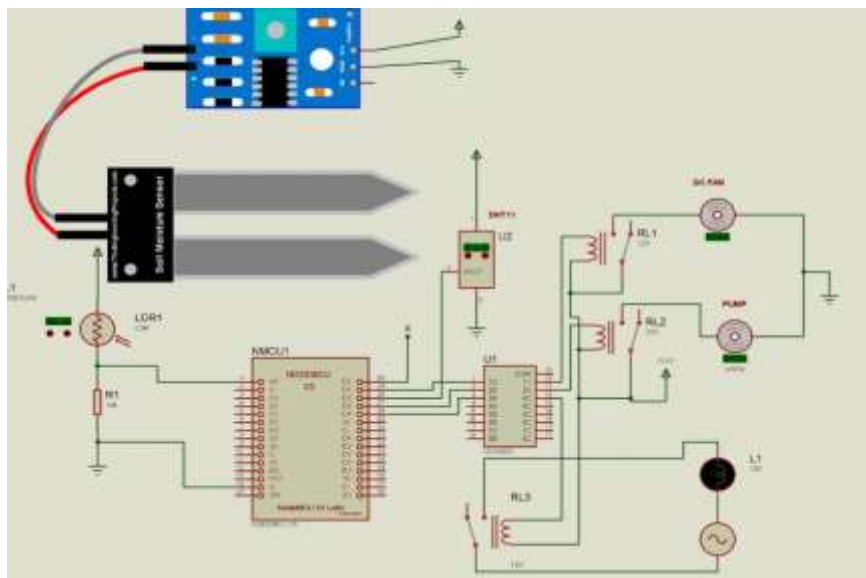

Figure.2 Schematic Diagram

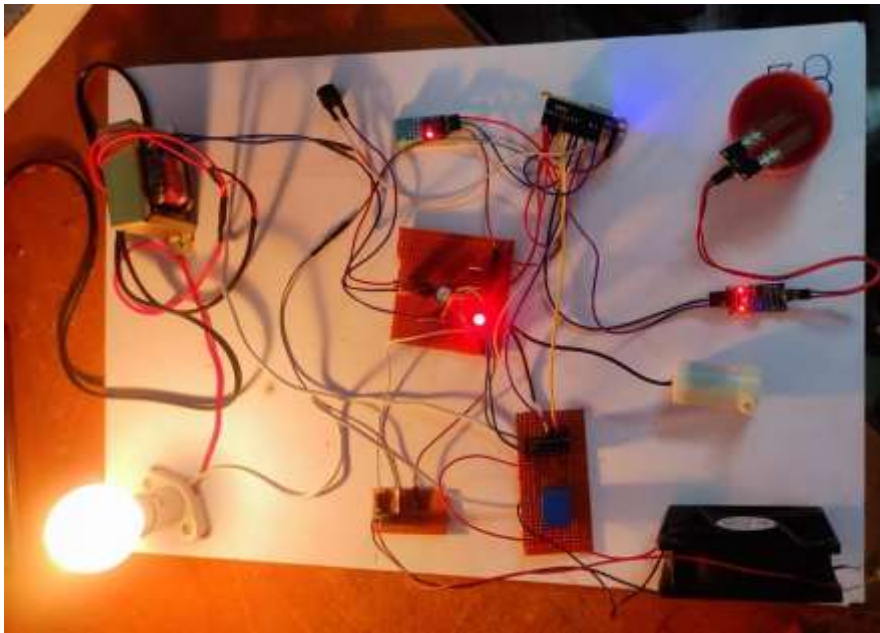

Figure.3 Working Kit

## RESULTS

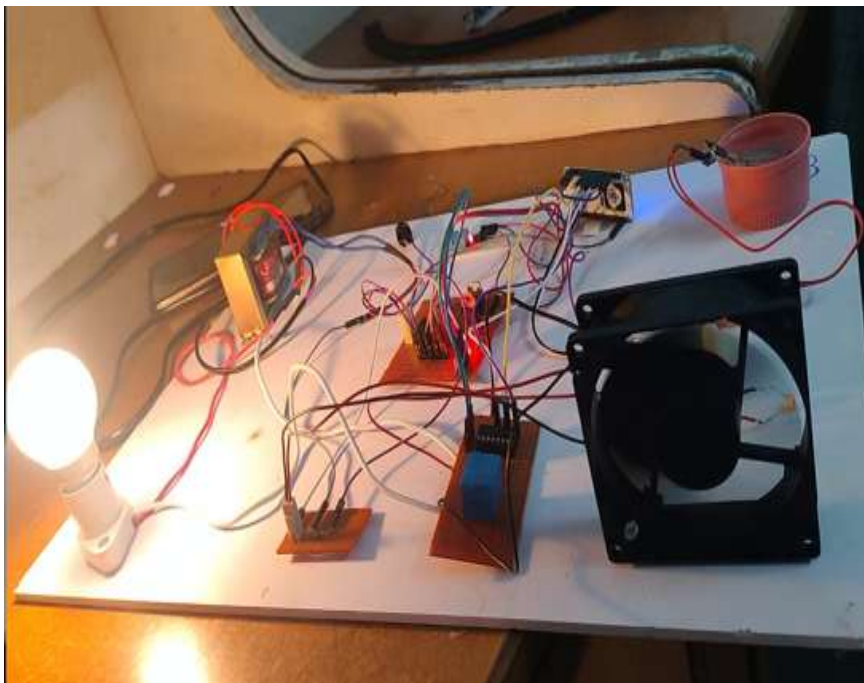

Figure.4 Light and Fan ON status



Figure.5 Dry soil condition

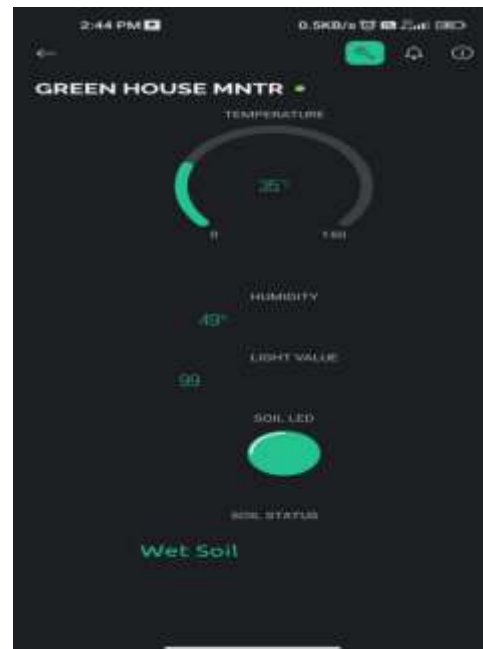
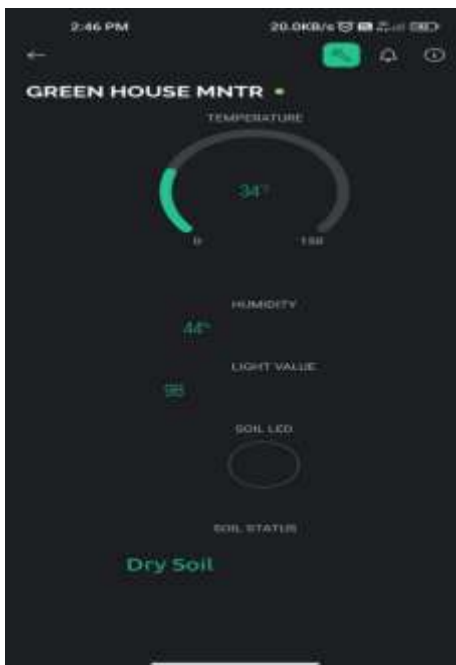

Figure.6 Status on Blynk output



Figure.7 Soil Wet condition

Figure.8 increasing the temperature

## APPLICATIONS

- 1.Real-time Monitoring:** Monitoring environmental factors such as temperature, humidity, soil moisture, light intensity, and CO2 levels to ensure optimal growing conditions for plants.
- 2. Remote Access:** Allowing growers to remotely monitor and control greenhouse conditions from anywhere using a smartphone or computer, which enables timely interventions and adjustments.
- 3. Automated Control:** Implementing automated control systems to regulate conditions based on predefined parameters, such as automatically adjusting temperature or irrigation systems.
- 4. Resource Optimization:** Optimizing resource usage, such as water and energy, by using data-driven insights to minimize waste and maximize efficiency.
- 5.Crop Management:** Providing insights into crop health and growth stages, enabling growers to make informed decisions regarding fertilization, pest control, and harvesting schedules.

## ADVANTAGES

- 1.Remote Monitoring and Control

2. Real-time Data
3. Optimized Resource Usage
4. Increased Efficiency

## CONCLUSION

In conclusion, implementing an IoT-based greenhouse monitoring and controlling system offers a transformative solution for modern agriculture. By seamlessly integrating sensors, actuators, and data analytics, this technology enables growers to optimize environmental conditions, enhance crop yields, and minimize resource wastage. Through remote monitoring and real-time control capabilities, growers can efficiently manage greenhouse operations from anywhere, maximizing productivity and minimizing manual intervention.

## FUTURE SCOPE

**1.Integration with AI and Machine Learning:** Incorporating AI and machine learning algorithms can enhance predictive analytics capabilities, enabling more accurate forecasting of crop growth, pest outbreaks, and environmental conditions. This integration can also automate decision-making processes and optimize greenhouse operations further.

**2.Edge Computing:** Implementing edge computing technology can process data closer to its source, reducing latency and improving response times. This approach is particularly beneficial for real-time monitoring and control applications in greenhouses, where timely interventions are critical.

**3.Sensor Technology Advancements:** Continuous advancements in sensor technology, including miniaturization, increased sensitivity, and lower costs, will lead to more affordable and robust monitoring solutions. These sensors may also become more specialized, catering to specific crop types or environmental parameters.

**4.Interoperability and Standardization:** Developing interoperability standards and protocols will facilitate seamless integration of diverse IoT devices and platforms within greenhouse environments. This interoperability will enable growers to mix and match solutions from different vendors while ensuring compatibility and ease of use.

## REFERENCES

Here are some references for your IoT-based greenhouse monitoring and controlling system project:

1. "Internet of Things (IoT) for Smart Agriculture: Technologies, Challenges, and Opportunities" by Muhammad Usman and Muhammad Zubair Asghar.
2. "Greenhouse Automation and Control Using Internet of Things (IoT)" by Pooja Deshmukh, Dipali Gore, and Prachi Palsokar.
3. "IoT-based Greenhouse Monitoring and Controlling System using Arduino and ThingSpeak" by Divya Dharshini and N. Shanmugavadivu.
4. "Design and Implementation of an IoT Based Greenhouse Monitoring and Controlling System" by Folorunso Olajumoke and Adetunmbi Ayodeji.
5. "Wireless Sensor Networks for Greenhouse Monitoring: A Review" by Sotiris Nikolettseas, Petros Belsis, and Evaggelia Pitoura.
6. "A Survey of Internet of Things (IoT) Technologies for Greenhouse Environment Monitoring and Control" by Nabil Seddiki and Rachid Benabbou.