

NEW GENERATION LED SCROLLING BOARD FOR ADVERTISEMENTS OVER IOT TECHNOLOGY

Mrs. N. LAKSHMI KALYANI¹, M. JYOTHI², K. C. S. POSU KUMAR³

¹Assistant Professor, Dept. of ECE, PRAGATI ENGINEERING COLLEGE

²³UG Students, Dept. of ECE, PRAGATI ENGINEERING COLLEGE

ABSTRACT

Notice boards are playing a very important role in our day-to-day life. By replacing conventional Analog type notice board with digital notice board, we can make information dissemination much easier in a paperless community. Notice board could be a primary factor in any establishment or public places like bus stations, railway stations, colleges, malls etc. Sticking out numerous notices day to day could be a tough method. A separate person is needed to take care of this notice display.

The objective of our project is to design an 8X64 LED dot-matrix (MAX 7219) moving message display using microcontroller and IOT where the characters shift from left to right continuously. In this project we have used Node MCU microcontroller. Node MCU is a family of ESP8266 developed boards. This project is regarding advanced wireless notice board. In IOT based Web Controlled Notice Board, Internet is employed to wirelessly send the message from Browser to the LED display. The main objective of the project is to develop a wireless notice board that displays messages sent from the user's mobile application.

INTRODUCTION

The project aims at designing a LED based scrolling message display control LED from an android mobile phone. The proposed system makes use of wi-fi technology to communicate from android phone to LED display board. This project is to develop based on IOT technology, which is used for spontaneous advertisement using LED's by using wi-fi. Now a day's every advertisement or information is displayed digitally. The big shops and shopping malls are using the digital moving/scrolling displays now. In railway stations and bus stands, everything that is ticket information, platform number etc is displaying in digital moving display. But in these displays if they want to change the message, they can send message through using wi-fi through your mobile phone by using this project. If they want to display messages about something

crucial within minimum time, it displays whatever wants. LED displays are used in variety of applications, like store signs, billboards and many more. In recent years it is commonly used in destination signs on public transport vehicles. LED panels are also used for the purpose of general illumination, task lighting and for stage lighting. Display systems are classified into single line displays, and multiline displays. A standard LED display board consists of LED lights arranged in 4 sets of 8 rows x 8 columns of dot-matrix display of common cathode, with the length of character is 8x8. Displays boards of any length and breadth can be made by combining more than one of these standard units. These display units are capable of displaying messages of any kind, including alphanumeric, numbers etc., in static or scrolling formats. This system is comprised of a red colour matrix display panel. It also includes an executive program that runs on the NODEMCU microcontroller for the display control of data information on the display board. LED provides several advantages over traditional light bulbs, such as small size and longer life. A red colour LED can be used to advertise even day-light conditions. The LED display board displays images and messages entered by using a microcontroller. The LED display board is very efficient and cost-effective way to spread messages to thousands of people, without any personal contact or door to door sales.

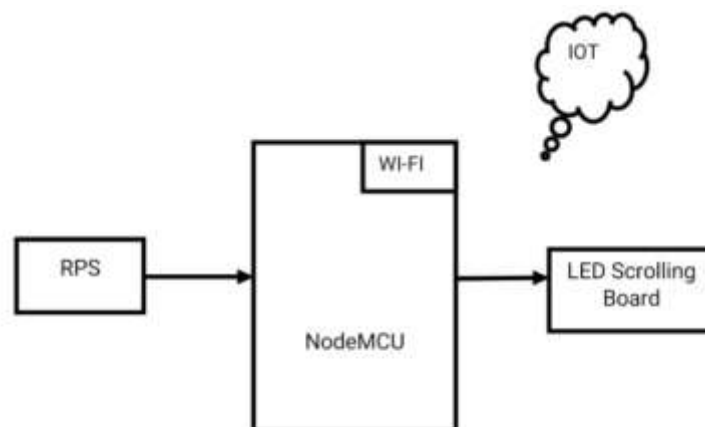

Figure.1 Block Diagram

LITERATURE SURVEY

Introduction to IoT in LED Scrolling Boards for Advertisements:

Start with an overview of the role of IoT in LED scrolling boards for advertisements, emphasizing the potential for dynamic content delivery, remote management, and audience engagement.

Explore literature that discusses the evolution of traditional static billboards to interactive and connected LED displays enabled by IoT technology.

Design and Architecture of IoT-Based LED Scrolling Boards:

Investigate research papers and articles that discuss the design principles and architecture of IoT-based LED scrolling boards.

Look for studies that describe the integration of LED modules, microcontrollers, communication protocols, cloud platforms, and content management systems to enable real-time updates and remote control.

IoT Communication Protocols and Standards:

Review literature on communication protocols and standards used in IoT-based LED scrolling boards.

Explore studies that discuss protocols such as MQTT, CoAP, HTTP, or WebSocket, and standards like Zigbee, LoRaWAN, or Wi-Fi for connecting LED displays to IoT networks and cloud platforms.

Content Management and Scheduling:

Examine research papers and articles that explore content management and scheduling techniques for IoT-based LED scrolling boards.

Look for studies that describe how advertisers can upload, schedule, and target advertisements remotely using web-based interfaces, APIs, or mobile apps connected to the cloud platform.

Dynamic Content Generation and Personalization:

Investigate literature on dynamic content generation and personalization features in IoT-based LED scrolling boards.

Explore studies that discuss how advertisers can leverage data analytics, user segmentation, and AI-driven algorithms to create personalized and context-aware advertisements tailored to specific audiences and locations.

Integration with External Data Sources:

Review research papers and articles that discuss the integration of IoT-based LED scrolling boards with external data sources.

Look for studies that describe how real-time data streams from sources such as weather APIs, social media feeds, traffic updates, or IoT sensors can be used to dynamically update content and enhance audience engagement.

PROPOSED SYSTEM

The proposed system is designed to avoid the existing system. With the help of this we can send the data/text without any errors. The proposed system requires less hardware structure compared to the existing system. The dot-matrix LED board appears smaller in size and easy carry and install but highly efficient and effective luminous will be provided and power consumptions is highly reduced by these display board.

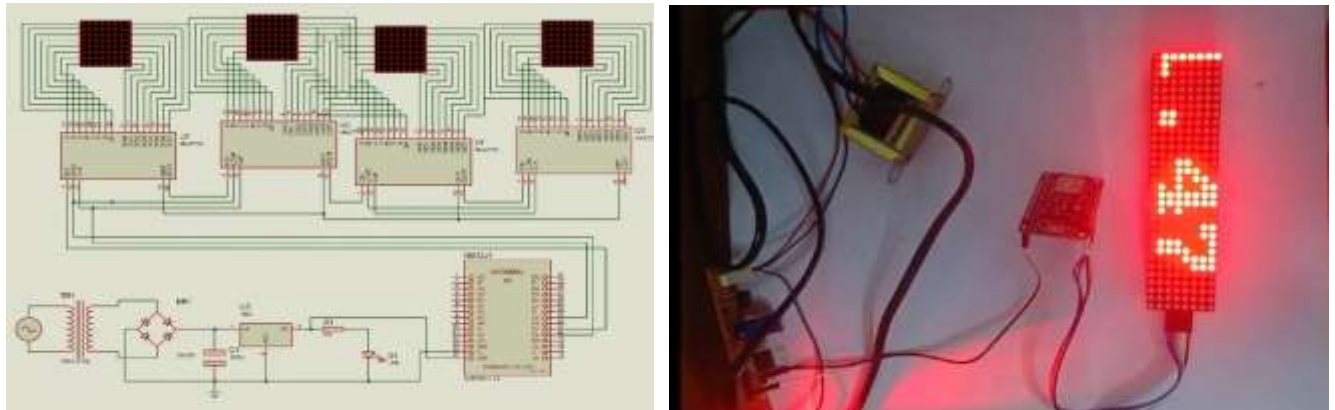

ADVANTAGES

- Slim design
- Brighter and sharper messages
- Better colour
- No motion delay and lags
- Longer lifespan and less environmental impact
- Lower power consumption
- Wider viewing angle (typically 175 degree)

APPLICATIONS

In Schools, Colleges and Universities: for displaying messages. Eg: placement news, student results, cultural activities news etc.

In Hotels: to display the availability of the rooms, welcome notices, the type of rooms and the cost of all items.

In Banks to display special schemes, new plans and various services of them.

In Airports to displays arrival and departure timings of planes and special attention messages.

Restaurants: to display the menu and offers etc.

In Railways stations to display platform numbers arrival and departure timings of trains. And special attention messages.

Nursing Homes: to display the staff attendance, the availability of the doctors, the list of the specialized doctors, no of patients etc.

RESULTS

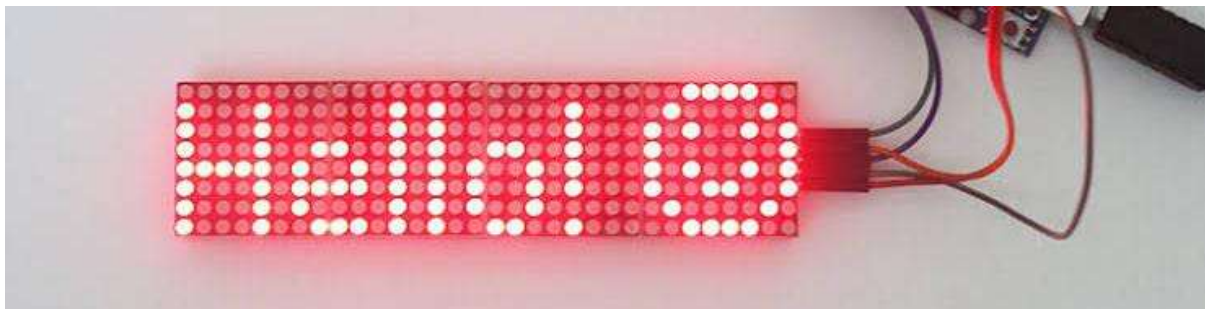

Figure.7 Message Display on Scrolling Board

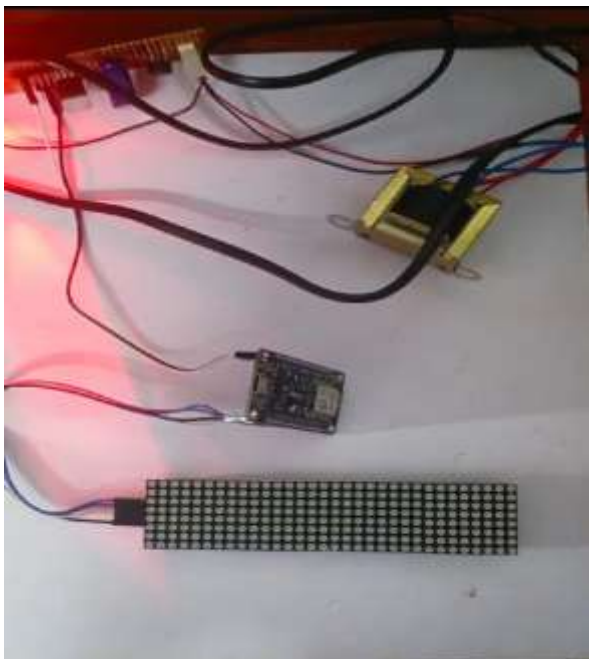

Figure.8 Project Setup

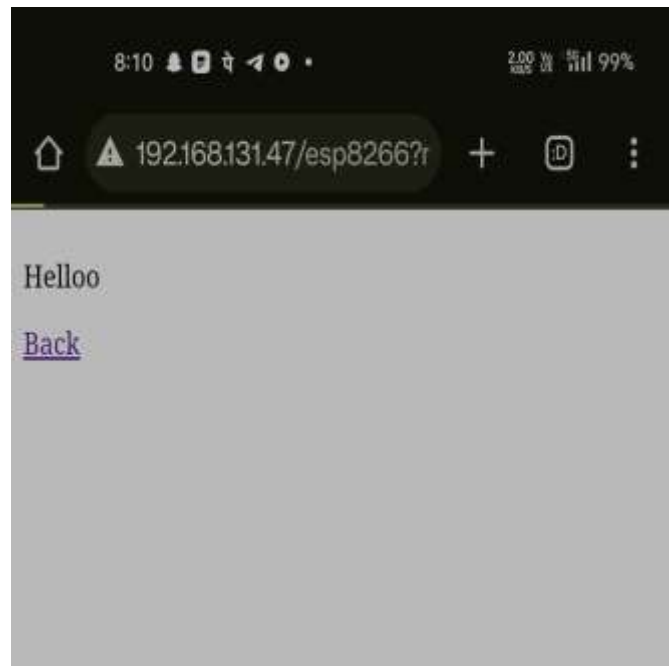

Figure.9 Displaying text on web

CONCLUSION

The introducing concept of wireless technology using WIFI in the field of communication we can make our communication more efficient and faster, with higher efficiency. We can display the messages with less errors and maintenance. This model can be used very efficiently used in schools, chain restaurants in colleges where in students and staffs can be informed simultaneously in time. It will used at public transport places like railways, bus station, and airport and also at roadside for traffic control and in emergency situations. It is cost efficient system and user friendly. Latency involved in using of papers in displaying of notices is avoided and the information can be updated by the authorized persons.

FUTURE SCOPE

The proposed system of scrolling display has limitations such as distance i.e., up to 100 meters. But the distance can be improved using RF zigbee modules where two sections such as RX and TX sections are need to develop. The text messages can be given from PC or keypad. Even sending of scrolling text can be done with unlimited distance using SMS mode. The system can use GSM technology which allows user to text from any distance, but it requires mobile signal strength.

REFERENCES

1. Gao W., Zhang, G. and Jiang, X. "Study Implementation of Agricultural SMS Management System". In Proceedings of IEEE International Conference on Information Technology and Computer Science, 13-17 October 2009, Beijing, China, pp. 1-4, 2009.
2. Shereen N. Z., and Rozumah B. "Mobile Phone use Amongst Student in University in Malaysia: It correlates and relationship to Psychological Health". European Journal of Scientific Research. Vol. 37. No.2. pp. 206 – 218, 2009.
3. Bollen, L., Eimler, S. and Hoppe, H.U. "SMS-based Discussions–Technology Enhanced Collaboration for a Literature Course". In Proceedings of the 2nd IEEE International Workshop on Wireless and Mobile Technologies in Education, 24- 27 May 2004, Germany, pp. 1-2, 2004.
4. Deng chunjjan, Liu Wei, Zou Kun, Yang Liang "A Solution of LED Large Screen Display Based On Wireless Communication",10.1109/apwcs.2010.24.
5. The 8051 Microcontroller and Embedded System Using Assembly and C by Muhammad Ali Mazidi.