

# Design and Development of Smart Door Lock System Over IoT Cloud

Mr. MANGINA BRAHMARAJU<sup>1</sup>, VANUM JAGADEESH<sup>2</sup>, PURLI BHAGYA KIRAN<sup>3</sup>

<sup>1</sup>Assistant Professor, Dept. of ECE, PRAGATI ENGINEERING COLLEGE

<sup>23</sup>UG Students, Dept. of ECE, PRAGATI ENGINEERING COLLEGE

## ABSTRACT

This paper presents the design and development of a smart garage door system, which is operated by an Arduino microcontroller via the use of a mobile application and the Blynk cloud sever. Further, this mobile application allows the smart garage door to be controlled and accessed from any remote location via the use of the Blynk cloud server which is connected to the Internet using Wi-Fi or 3G/4G network. The operations of this smart door lock and unlock system is useful for house, colleges, authorized rooms, car garage systems. Finally, this smart door application has been tested and it is able to successfully perform the basic operations of a smart garage door as proposed in the initial design and development stage.

## INTRODUCTION

In the rapidly evolving landscape of the Internet of Things (IoT), the integration of smart technologies into everyday devices has become a hallmark of modern innovation. One such area where IoT can revolutionize conventional systems is in home security, with a focus on enhancing the traditional door lock mechanism. The "Design and Development of a Smart Door Lock System over IoT Cloud" project addresses the need for advanced security solutions that seamlessly blend technology and convenience.

Traditional door locks, while effective, often lack the adaptability and remote accessibility required in today's fast-paced and interconnected world. The proposed smart door lock system aims to bridge this gap by leveraging IoT technologies and cloud connectivity. This innovative approach not only enhances the overall security of residential and commercial spaces but also provides users with unprecedented control and monitoring capabilities.

By integrating the smart door lock system with the IoT cloud, users can remotely manage and monitor access to their premises, receive real-time notifications, and customize security settings from anywhere in the world. The project will delve into the design and development aspects, exploring the integration of cutting-edge hardware components, robust software

algorithms, and secure cloud infrastructure to create a comprehensive and reliable smart door lock system.

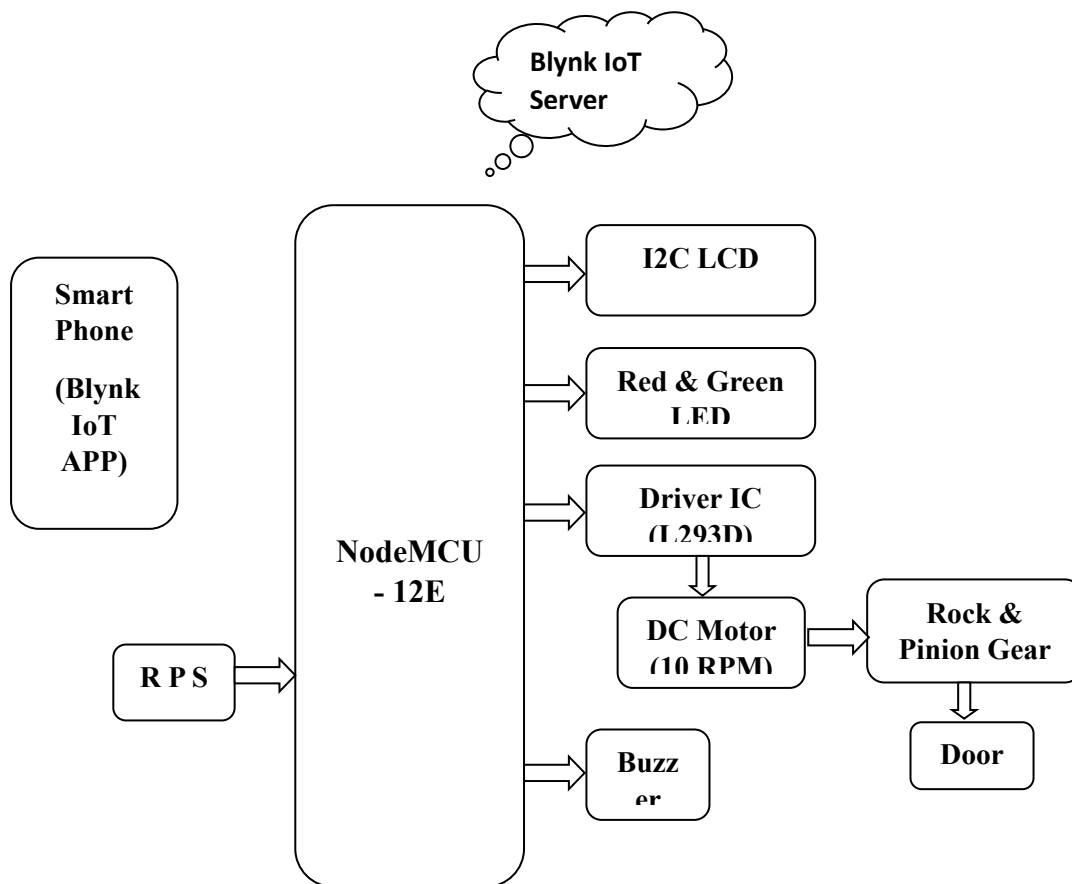

Figure.1 Block Diagram

## LITERATURE SURVEY

### Introduction to Smart Door Lock Systems Over IoT Cloud:

Start with an overview of smart door lock systems and their integration with IoT cloud platforms.

Explore literature discussing the benefits of smart door locks, such as enhanced security, convenience, and remote access control, when integrated with cloud-based IoT solutions.

### Design and Architecture of Smart Door Lock Systems:

Investigate research papers and articles that discuss the design principles and architecture of smart door lock systems over IoT cloud. Look for studies that describe the integration of sensors, actuators, microcontrollers, communication modules, and cloud platforms to enable remote locking and unlocking, user access management, and activity logging.

**IoT Communication Protocols and Standards:**

Review literature on communication protocols and standards used in smart door lock systems over IoT cloud.

Explore studies that discuss protocols such as MQTT, CoAP, HTTP, or Bluetooth Low Energy (BLE), and standards like Zigbee, Z-Wave, or Wi-Fi for connecting door locks to IoT cloud platforms.

**Security Features and Authentication Mechanisms:**

Examine research papers and articles that explore security features and authentication mechanisms in smart door lock systems over IoT cloud.

Look for studies that discuss encryption techniques, access control policies, authentication protocols (e.g., OAuth, JWT), and biometric authentication methods to ensure secure access and prevent unauthorized entry.

**Remote Access Control and Monitoring:**

Investigate literature on remote access control and monitoring functionalities in smart door lock systems over IoT cloud.

Explore studies that describe how users can remotely lock or unlock doors, grant temporary access permissions, receive notifications of door activities, and monitor access logs using mobile apps or web portals connected to the cloud platform.

**PROPOSED SYSTEM**

The smart garage door system operates on an Arduino microcontroller, serving as the central processing unit that orchestrates the communication between the physical components and the Blynk cloud server. The system is designed to provide remote control and monitoring capabilities through a dedicated mobile application.

A mobile application, developed using the Blynk platform, acts as the user interface for controlling the smart garage door. Users can download the application on their smartphones and establish a connection with the Blynk cloud server. The Blynk cloud server facilitates seamless communication between the mobile application and the Arduino microcontroller, enabling real-time control and monitoring.

A transformer has been connected to the regulated power supply(RPS) and the RPS will send the needed power to the remaining components.

The RPS will be connected to the NODEMCU-12E where it has an inbuilt WIFI chip embedded in it which a connection between the Blynk app and the NODEMCU. The NODEMCU has connections with the DC motor, LCD Display, Driver IC and Blinking LEDs.

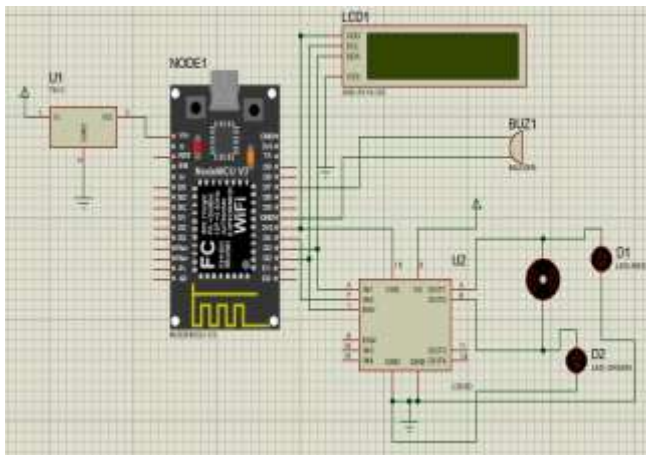

Figure.1 Schematic Diagram



Figure.2 Working kit

## RESULTS

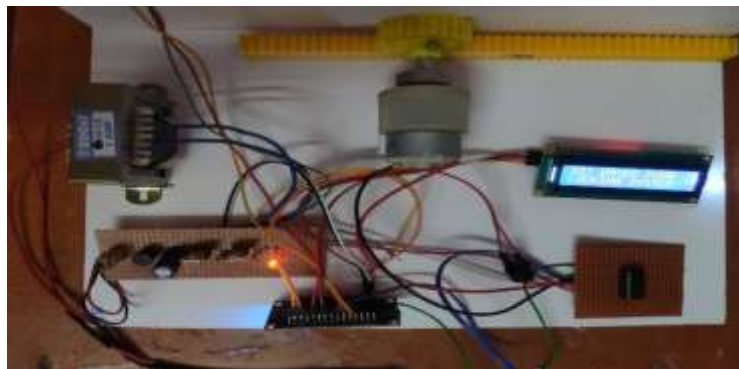

Figure.3 Output

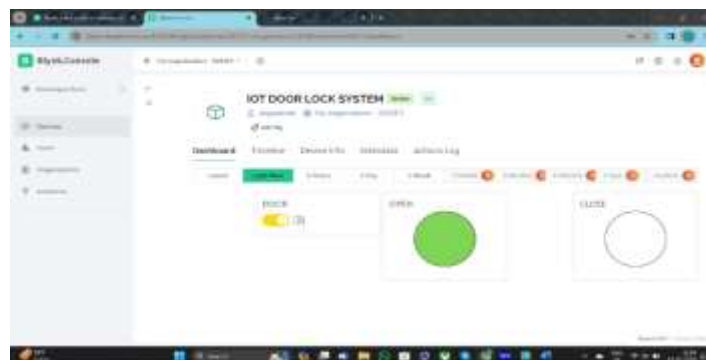

Figure.4 Status of Door (OPEN)

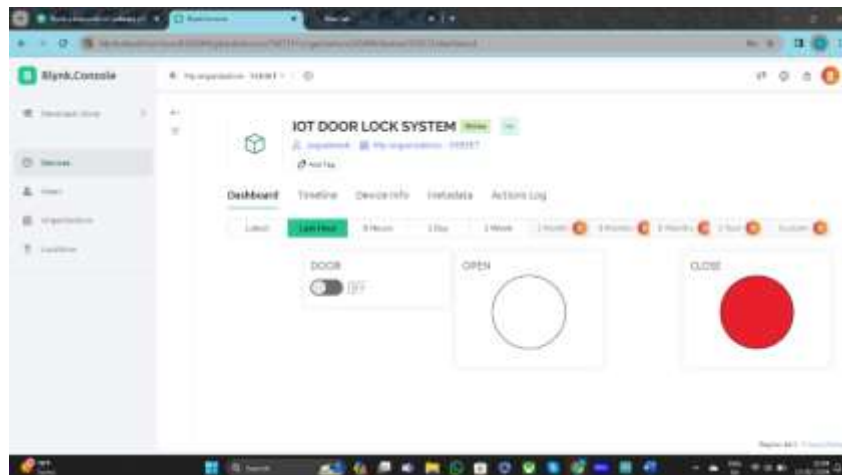

Figure.5 Status of Door CLOSED

## APPLICATIONS

There are several applications of Door lock system using IoT(internet of Things).Here are the few examples

- Home Garage Door
- Commercial Garages/Storage Facilities
- Industrial Warehouses
- Integration with Smart Home Systems

## ADVANTAGES

- 1. Enhanced Security:** Protects property, assets, and inventory from unauthorized access.
- 2. Burglary Deterrent:** Acts as a strong deterrent, reducing the risk of break-ins.
- 3. Convenience:** Offers easy and customized access through features like keyless entry and remote control.
- 4. Peace of Mind:** Provides assurance and confidence in overall security.
- 5. Valuables Protection:** Safeguards vehicles, tools, and high-value items from theft.
- 6. Smart Technology Integration:** Allows for remote monitoring and control via mobile devices.
- 7. Safety Improvement:** Enhances safety by restricting access to potential hazards.

**8. Customization:** Users can tailor access permissions, adding a personalized layer to security measures.

## **CONCLUSION**

In conclusion the Door Lock System using IoT can Significantly improve the Door Operations Efficiently and with enhanced security. The device's integration with other smart devices and the use of WIFI technology, sensors, and Blynk App Usage and operation can make it a comprehensive safety system.

The device integration with many aspects can increase the Door opening and closing operations, can able to operate with online options with ease.

## **FUTURE SCOPE**

The future scope for Door Lock System using IoT is vast, promising and huge benefits.

1. **Advanced Technology Integration:** Expect door lock systems to get smarter with technologies like AI and IoT, making them more intelligent and adaptable.
2. **Better Biometrics:** Future systems may use improved biometrics like fingerprints or facial recognition for more secure and user-friendly access.
3. **Predicting Threats:** Door locks might use predictive analytics to foresee security threats and adjust access controls in advance.
4. **Energy Efficiency:** Future systems could be more energy-efficient, using smart sensors to optimize power consumption based on usage patterns.
5. **Temporary Access Codes:** Anticipate door lock systems with features allowing temporary or one-time access codes for shared spaces or short-term permissions.
6. **Customization and User-Friendly Features:** Continued focus on easy-to-use interfaces and customizable options to make security solutions personalized and user-friendly.

## **REFERENCES**

- [1] Zeydin Pala and Nihat Inan, "Smart parking application using RFID technology", RFID Eurasia, 1st Annual in RFID Eurasia, 2007.

- [2] Zhang, L., "An Improved Approach to Security and Privacy of RFID application System", Wireless Communications, Networking and Mobile Computing. International Conference. Pp 1195- 1198, 2005.
- [3] Xiao, Y., Yu, S., Wu, K., Ni, Q., Janecek., C., Nordstad, J,"Radio frequency identification: technologies, applications,and research issues" Wiley Journal of Wireless Communications and Mobile Computing, Vol 7, May 2007.
- [4] Goodrum, P., McLaren, M., Durfee, A.," The application of active radio frequency identification technology for tool tracking on construction job sites." Automation in Construction, 15 (3), 2006, pp 292-302.
- [5] R. Weinstein, "RFID: a technical overview and its application to the enterprise," IT Professional, vol. 7, pp. 27 -33, May-June 2005.
- [6] Yu-Chih Huang;"Secure Access Control Scheme of RFID System Application",Fifth International Conference on Information Assurance and Security, China, 2009.
- [7] S. Shepard, "RFID Radio Frequency Identification", USA, ISBN: 0-07-144299-5, 2005.
- [8] Mandeep Kaur, Manjeet Sandhu, Neeraj Mohan and Parvinder S. Sandhu RFID Technology Principles, Advantages, Limitations & Its Applications, IJCEE, Vol.3, No.1, February, 2011 1793-8163.