

## **MEMS CONTROLLED WHEEL CHAIR FOR PATIENTS AND PHYSICALLY CHALLENGED PERSONS**

Mrs. P. RAMYA KRISHNA<sup>1</sup>, A. KUNDANA SRI SAI SUDHA<sup>2</sup>, K. SAI SHIVANI<sup>3</sup>

<sup>1</sup>Assistant Professor, Dept. of ECE, PRAGATI ENGINEERING COLLEGE

<sup>23</sup>UG Students, Dept. of ECE, PRAGATI ENGINEERING COLLEGE

### **ABSTRACT**

With the advancement of science and Technology an innovative mechanism is adopted to provide the assistance for physically challenged personalities. Spinal cord injury persons and physically challenged persons required human assistance to move from one point to another point. Electronics interfaced Wheel chair had designed to move without any assistance. Micro Electro Mechanical Systems (MEMS) based accelerometer sensor is used to direct the movement of the device. The wheel chair may move forward, backward, left and right directions based on the output signal of the MEMS device. This project is to develop a wheel chair control which is useful to the physically disabled person with his hand movement or his hand gesture recognition using MEMS technology. The use of powered wheel chair with high navigational intelligence is one of the great steps towards the integration of severely physically disabled people. Driving wheel chair in domestic environments is a difficult task for people with arm or hands impairments. The wheel chair is developed to overcome the above problem described above allowing the end users to just perform safe movements and accomplish some daily life important tasks.

### **INTRODUCTION**

The main aim of this paper is to controlling a wheel chair and electrical devices by using MEMS. MEMS accelerometer sensor is micro electro-mechanical sensor which is a highly sensitive sensor and capable of detecting the tilt. This sensor finds the tilt and makes use of the accelerometer to change the direction of the wheel chair depending on tilt. For example, if the tilt is to the right side, then the wheel chair moves in right direction or if the left side, then wheel chair left direction. Wheel chair movement can be controlled in forward. The sensors may be positioned to sense the head movement or to sense the gestures of the hand. This work considered the angle of tilt of the arm in order to determine the movement direction of the wheel chair. This project makes use of microcontroller, which is programmed, with the help of

C++. This microcontroller communicates with the ADC and motor driver. The MEMS Accelerometer Sensor based sensor detects tilt and provides the information to the microcontroller and the controller judges whether the instruction is right movement or left movement instruction and controls the direction respectively. The controller is interfaced with two dc motors to control the direction of the wheel chair. To perform the task the controller is loaded with intelligent program written using C++. The ultimate goal is to provide an innovative solution that enhances the mobility and accessibility of individuals with disabilities.

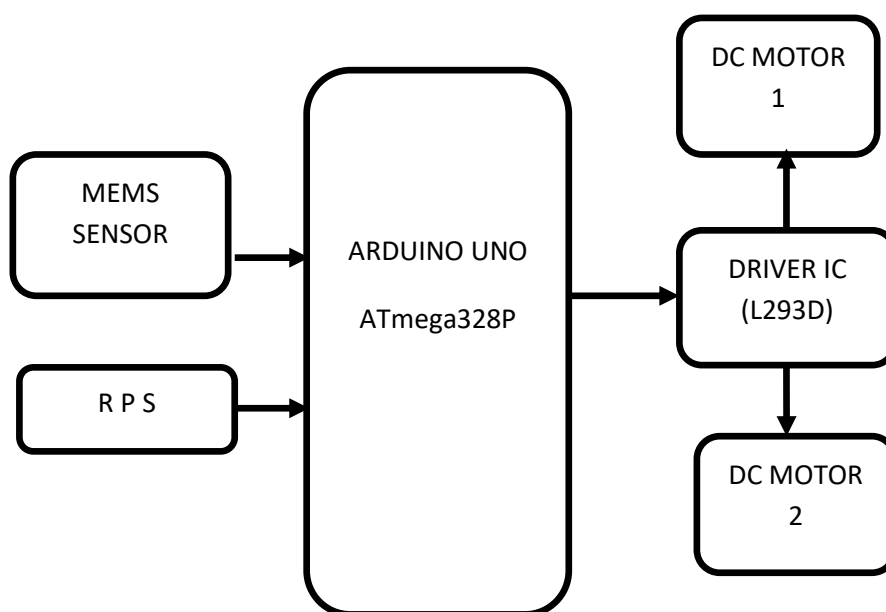

Figure.1 Block diagram

### OBJECTIVE OF THE PROJECT

The objective of the MEMS (Micro electro mechanical Systems) controlled wheelchair for patients project is to provide mobility assistance to patients with physical disabilities or limited mobility. MEMS technology enables the wheelchair to be controlled through precise and sensitive sensors, allowing users to navigate the wheelchair with minimal effort and maximum efficiency. The project aims to enhance the independence and quality of life for individuals with mobility impairments by offering them a reliable and easy-to-use means of transportation.

This project proposes an integrated approach to real time detection, tracking and direction recognition of hands, which is intended to be used as a human-robot interaction interface for the intelligent wheelchair. This paper is to demonstrate that accelerometers can be used to effectively translate finger and hand gestures into computer interpreted signals. For gesture

recognition the accelerometer data is calibrated and filtered. Develop a MEMS sensor-based control system that accurately interprets user inputs for controlling the wheelchair.

## **LITERATURE SURVEY**

### **1. MEMS Technology:**

Review literature related to MEMS technology, including sensors, actuators, and control mechanisms. Understand the principles, applications, and advancements in MEMS devices that can be integrated into wheelchair control systems.

### **2. Wheelchair Control Systems:**

Explore research papers and articles focusing on different types of wheelchair control systems, such as joystick control, sip-and-puff systems, head array control, and brain-computer interfaces. Investigate the advantages, limitations, and user experiences associated with each control method.

### **3. Assistive Technologies for Mobility:**

Examine literature on assistive technologies designed to improve mobility and independence for individuals with disabilities. This may include studies on powered wheelchairs, robotic exoskeletons, smart mobility aids, and navigation assistance systems.

### **4. User-Centered Design:**

Look for research that emphasizes user-centered design principles in the development of assistive technologies. Understand the importance of involving end-users, caregivers, and healthcare professionals in the design, testing, and evaluation of MEMS controlled wheelchairs.

### **5. Human Factors and Ergonomics:**

Investigate literature on human factors and ergonomics related to wheelchair design and usability. Consider factors such as comfort, accessibility, safety, and user satisfaction in the development of MEMS controlled wheelchairs.

### **6. Clinical Trials and Evaluations:**

Identify studies and reports that present clinical trials, user studies, and evaluations of assistive technologies for mobility-impaired individuals. Analyze the outcomes, challenges, and recommendations derived from these trials to inform the design and implementation of MEMS controlled wheelchairs.

### PROPOSED SYSTEM

This project differs from existing wheelchair as it incorporates hand gesture recognition technology utilizing acceleration sensors (accelerometers). This allows users to control the wheelchair through intuitive hand movements, providing a more accessible and natural interface, particularly beneficial for individuals with limited mobility, such as quadriplegics. The proposed system aims to enhance independence, simplicity, responsiveness, accessibility, and portability while potentially reducing costs compared to existing MEMS-controlled wheelchairs.

The aim of the paper is to develop a wheelchair control system that allows users to navigate without assistance. By using hand gestures, even quadriplegics can operate the wheelchair independently. The system involves real-time detection and tracking of hand movements, enabling the wheelchair to respond accurately to the user's gestures.

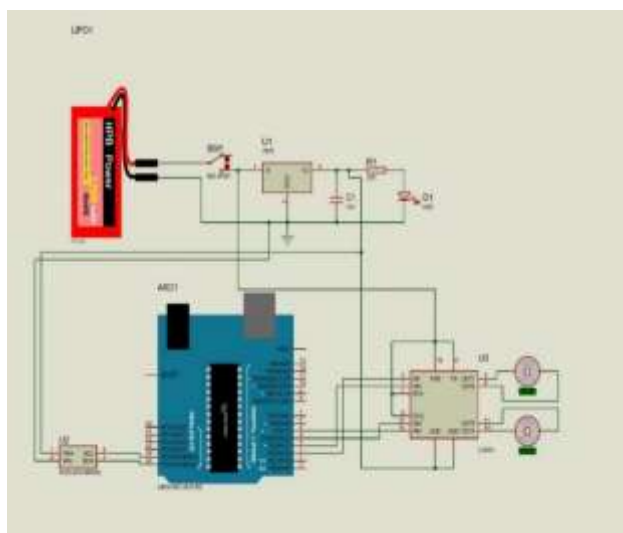

Figure.2 Schematic Diagram

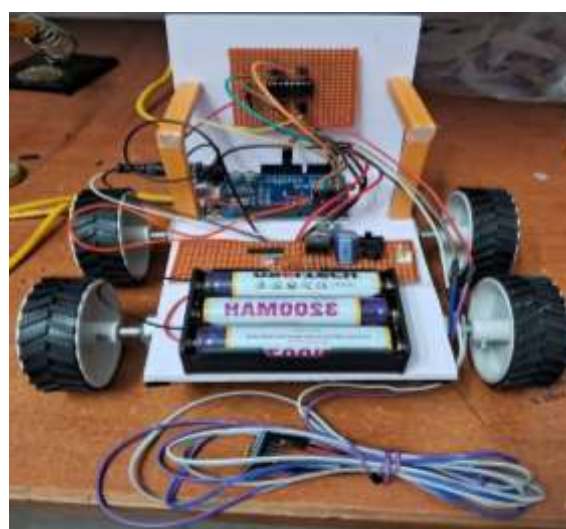

Figure.3 Working kit

### RESULTS

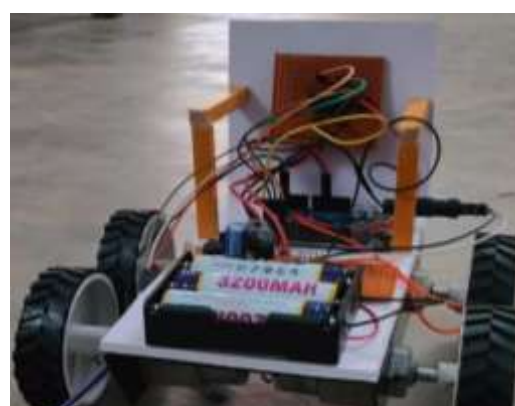

Figure.4 MEMS towards right

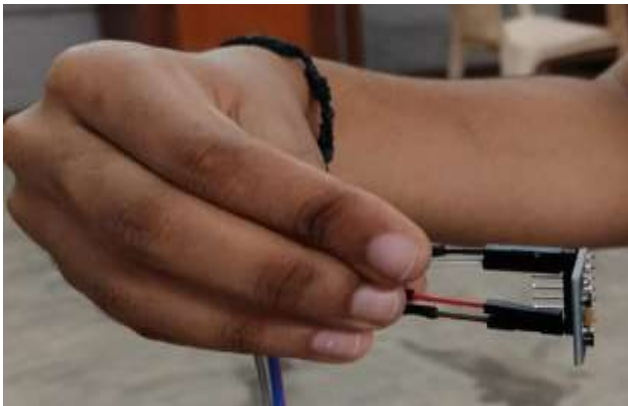

Figure.5 MEMS towards

Figure.5 Chair moving towards right



Figure.6 Chair moving towards left

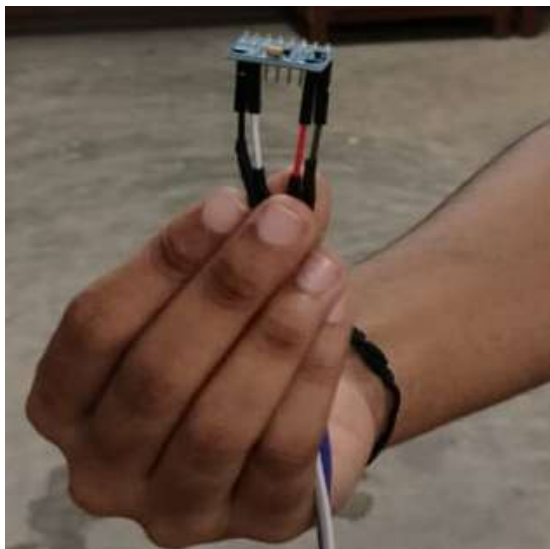

Figure.7 MEMS towards top

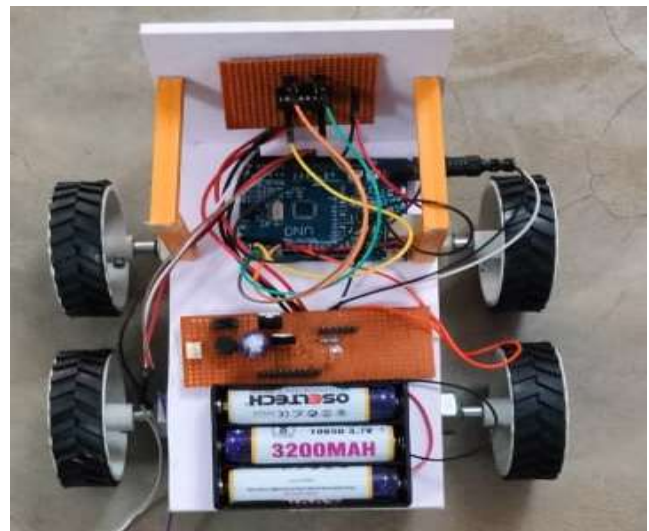

Figure.8 Chair moving towards forward



Figure.9 MEMS moving down

Figure.10 Chair moving towards backward

**PROPOSED SYSTEM**

- Low cost
- Simplicity

**CONCLUSION**

In conclusion, the wheelchair control system designed to assist physically disabled individuals through hand gesture recognition technology. Despite notable progress in wheelchair technology, quadriplegics still face challenges in navigating wheelchairs independently. By leveraging acceleration sensors, the system interprets hand gestures to maneuver the wheelchair accordingly. The integration of accelerometers enables real-time detection and translation of hand movements, facilitating precise control over wheelchair direction. Additionally, it proposes an integrated approach for detecting, tracking, and recognizing hand gestures in real-time, offering potential applications in human-robot interaction interfaces for intelligent wheelchairs. Through careful calibration and filtering of accelerometer data, the system demonstrates effective gesture recognition capabilities. Looking ahead, the potential integration of wireless solutions and MEMS accelerometers could lead to the development of compact, wearable devices, further enhancing accessibility and autonomy for individuals with physical disabilities.

**REFERENCES**

[1] Diksha Goyal and Dr. S.P.S. Saini,” Accelerometer Based Hand Gesture Controlled Wheelchair”, International Journal on Emerging Technologies 4(2): 15-20, 2013.

- [2] Javajji Veeraiah et.al, “Accelerometer Based Gesture Recognition for Wheel Chair Direction Control using ZIGBEE Protocol”, International Journal of Technological Exploration and Learning, vol 2(2): 104-108, April 2013.
- [3] Sukhmeet Kaur and Hem Chand Vashist, “Sukhmeet Kaur<sup>1</sup> and Hem Chand Vashist<sup>2</sup>”, Advance in Electronic and Electric Engineering, Volume 3(2): 227- 232, 2013.
- [4] Mohammed Asgar et.al, “Automated innovative wheel chair”, International Journal of Information Technology Convergence and Services (IJITCS) Vol.3, No.6, December 2013.
- [5] Shaik Meeravali, M. Aparna, “Design and Development of a Hand-glove Controlled Wheel Chair Based on MEMS”, International Journal of Engineering Trends and Technology (IJETT) – Volume 4(8): 3706-3712, August 2013
- [6] N.V. MaruthiSagar,” MEMS Based Gesture Controlled Robot Using Wireless Communication “, International Journal of Engineering Trends and Technology, Vol 14 (4): 185-188, Aug 2014
- [7] Mohammed Ismail.B et.al,” Head Gesture Based Control of Wheelchair for a Paralysed Person in an Indoor Environment”, international journal of innovative research in electrical, electronics, instrumentation and control engineering, Vol. 2(10):2079-2083, October 2014
- [8] Prof. Vishal V. Pande, et.al, “Hand Gesture Based Wheelchair Movement Control for Disabled Person Using MEMS”, Journal of Engineering Research and Applications, Vol 4 (4): 152-158, April 2014.
- [9] B. Ramana Reddy, J. V. Sharma, “Movement based and Voice enabled Device Switching for basic needs of Physically Challenged Persons”, International Journal of Science and Research, Vol. 2(3):137-139, March 2013.