

## **IOT BASED FIRE FIGHTING ROBOT**

Dr. J. SHARON ROSE VICTOR<sup>1</sup>, K. LAKSHMI SURYA BHAVANI<sup>2</sup>, M. JAYENDRA SAI  
CHAKRADHAR<sup>3</sup>

<sup>1</sup>Associate Professor, Dept. of ECE, PRAGATI ENGINEERING COLLEGE

<sup>23</sup>UG Students, Dept. of ECE, PRAGATI ENGINEERING COLLEGE

### **ABSTRACT**

Fire accidents have been occurring frequently these days, with or without the intervention of humans. A fire incident is a disaster that can potentially cause the loss of life, property damage, and permanent disability to the affected victims. Firefighters are primarily tasked to handle fire incidents, but they are often exposed to higher risks when extinguishing the fire, especially in hazardous environments such as nuclear power plants, petroleum refineries, gas tanks, etc. They also face other problems, especially if a fire breaks out in a small, cramped area, as they need to explore the ruins of buildings and obstacles to extinguish the fire and save the victim. In the case of high barriers and risks in firefighting activities, innovation can be used to assist the fire brigade. When the Robot detects a fire, it gives a message to the nodeMCU which will automatically sense the fire update the data on to blynk server and control the robot and start the water pump. It assists firefighters in extinguishing the fire. And it will perform its operation where firefighters can't reach. This will save the risk of fire fighters' life and avoid any further damage.

### **INTRODUCTION**

In order to put out fires and preserve lives, firefighters must be experienced and trained to enter dangerous places. This is a risky and difficult work. To improve the security and effectiveness of firefighting operations, fire fighting robotic vehicles have emerged as a potential alternative thanks to recent breakthroughs in robotics technology. Unmanned vehicles that are outfitted with sensors and firefighting gear may enter risky settings and carry out duties that would be too dangerous or complex for human firefighters. These vehicles are called firefighting robotic vehicles. These robotic devices may be operated remotely and are frequently furnished with firefighting tools. The ability of robotic firefighting vehicles to enter dangerous settings without endangering the lives of human firefighters lowers the possibility of injury or death. This is one of the key benefits of these vehicles. Robotic systems can also work continuously for

extended periods of time without stopping or resting, which is useful in circumstances where time is of the importance. To sum up, robotic firefighting vehicles provide a viable way to improve the security and effectiveness of firefighting operations. These systems are anticipated to grow increasingly complex, adaptable, and efficient in solving the issues encountered by firemen in hazardous areas as robotics technology continues to progress.

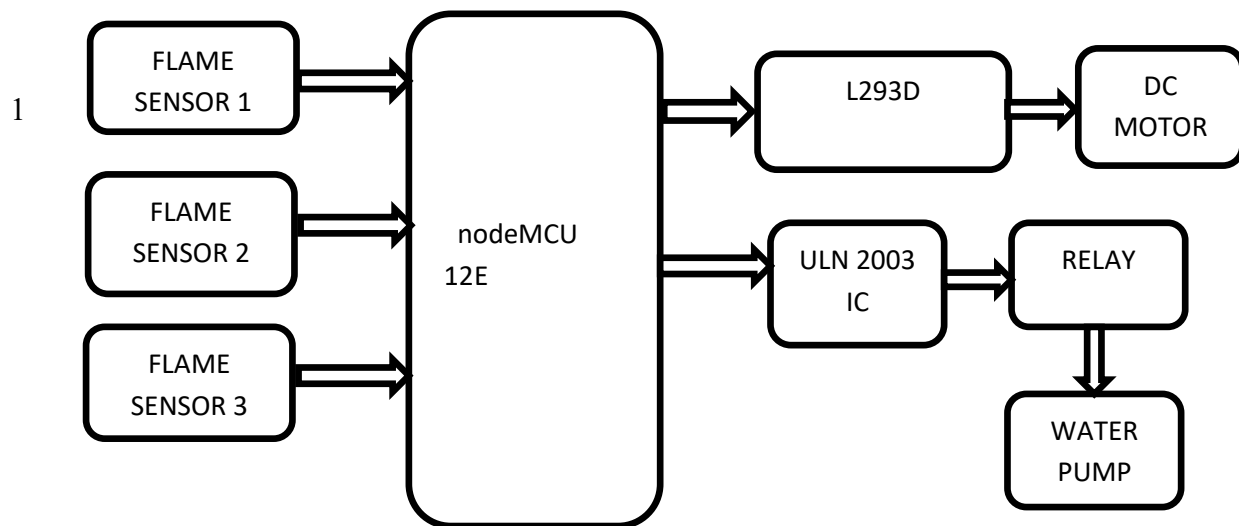

Figure.1 Block Diagram

### OBJECTIVE OF THE PROJECT

Develop a robotic system capable of detecting fires autonomously in various environments, including hazardous locations such as nuclear power plants, petroleum refineries, and gas tanks.

Implement functionality within the robotic system to navigate and maneuver through small, cramped areas and obstacles commonly encountered during firefighting operations. This includes exploring building ruins and overcoming high barriers to access fire-affected areas.

Enable the robotic system to initiate firefighting measures autonomously upon detecting a fire, including activating a water pump to extinguish the flames effectively.

Enhance the safety of firefighters by deploying the robotic system in scenarios where human intervention is limited or poses significant risks. This includes situations where access is restricted or the environment is too hazardous for human entry.

Minimize property damage and loss of life by providing timely and efficient firefighting support through the use of innovative robotics technology.

## **LITERATURE SURVEY**

### **Introduction to IoT in Fire Fighting Robots:**

Begin with an overview of the application of IoT in fire fighting robots and the need for advanced technologies to improve response time and safety.

Explore literature that discusses the challenges faced by traditional fire fighting methods and the potential benefits of integrating IoT capabilities into robotic systems.

### **Design and Architecture of IoT-Based Fire Fighting Robots:**

Investigate research papers and articles that discuss the design principles and architecture of IoT-based fire fighting robots.

Look for studies that describe the integration of sensors, actuators, microcontrollers, communication modules, and cloud platforms to enable autonomous operation, real-time data transmission, and remote control.

### **Sensor Technologies for Fire Detection and Monitoring:**

Review literature on sensor technologies used in IoT-based fire fighting robots for fire detection and environmental monitoring. Explore studies that discuss the deployment of sensors such as thermal imaging cameras, gas sensors, smoke detectors, temperature sensors, and humidity sensors to detect and assess fire hazards.

### **Autonomous Navigation and Mapping:**

Examine research papers and articles that explore autonomous navigation and mapping techniques for fire fighting robots.

Look for studies that discuss the use of SLAM (Simultaneous Localization and Mapping) algorithms, LiDAR sensors, computer vision systems, and GPS for navigation in complex environments and creating maps of fire scenes.

### **Fire Suppression Mechanisms:**

Investigate literature on fire suppression mechanisms used by IoT-based fire fighting robots.

Explore studies that discuss the deployment of water cannons, foam sprayers, extinguishing agents, or other suppression methods controlled remotely or autonomously by the robot.

### **PROPOSED SYSTEM**

This project differs from existing firefighting solutions by combining robotics, IoT technology, and autonomous capabilities to detect and extinguish fires in hazardous environments. Unlike traditional methods reliant on manual intervention, this system operates independently, minimizing risks to firefighters and enhancing efficiency in firefighting operations, especially in inaccessible or dangerous areas.

A fire fighting robot typically operates autonomously or can be remotely controlled. It is equipped with sensors to detect heat, smoke, or flames. These sensors help the robot identify the location and intensity of the fire. Robotic vehicle moves through the disaster area as per the instructions from the nodeMCU through the dc motor. Dc motor can be controlled through the L293D motor driver.

Whenever the temperature exceed a limit value on flame sensor then nodeMCU identifies that there is a presence of fire. NodeMCU processes the data from the sensors and operates the water pump through the relay.MCU operates the relay through the relay interface ULN2003 driver circuit.

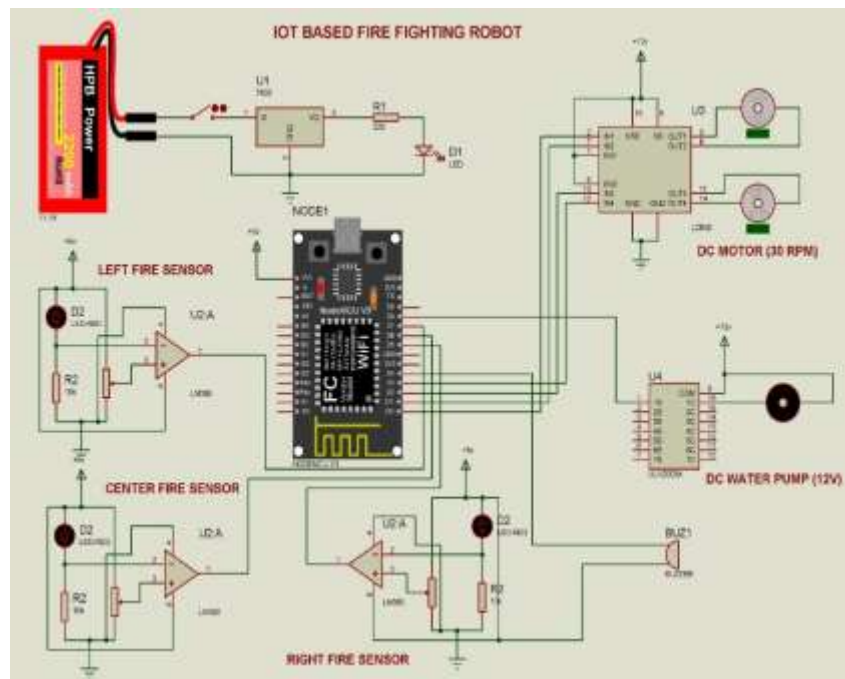

Figure.2 Schematic Diagram

## RESULTS

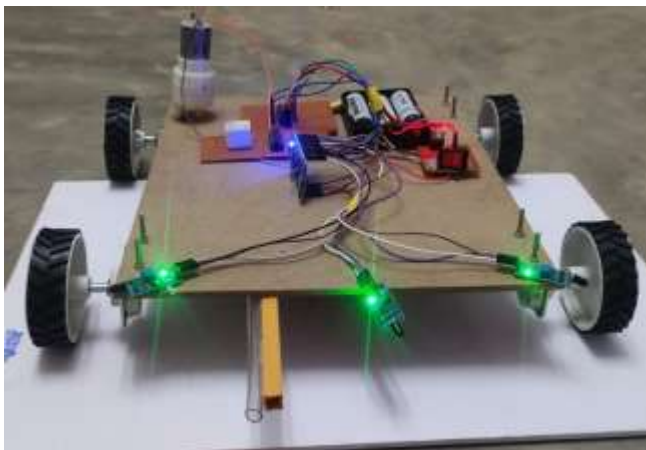

Figure.3 Working kit



Figure.4 Moving towards right

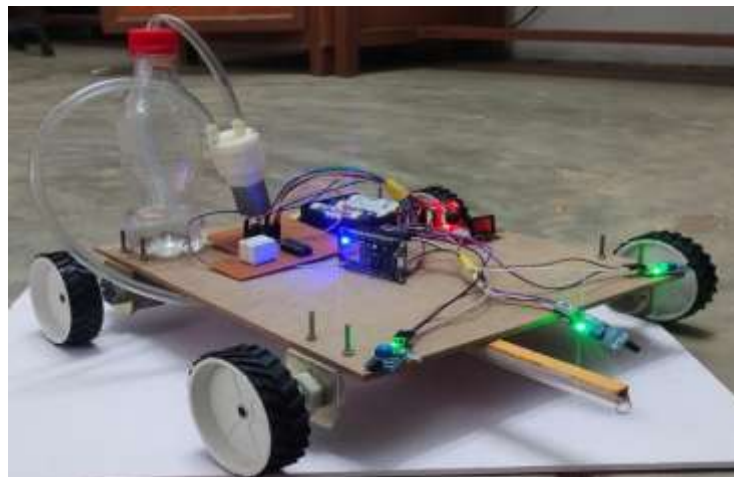

Figure.5 Moving Towards Left

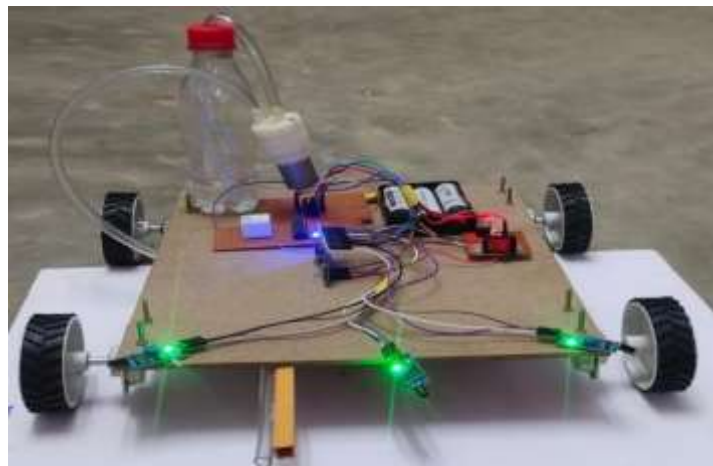

Figure.6 Moving Straight



Figure.7 Fire at center on Blynk

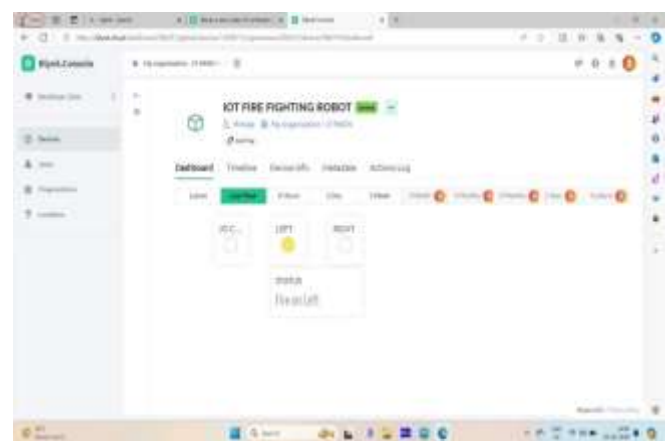

Figure.8 Fire at left on Blynk





Figure.9 Fire at right on Blynk

## CONCLUSION

Firefighting robots play a crucial role in enhancing firefighting capabilities by providing an autonomous or remotely controlled solution for combating fires. Equipped with specialized sensors, navigation systems, and firefighting mechanisms, these robots can efficiently detect and suppress fires in environments that may be challenging or hazardous for human intervention. Their ability to communicate real-time data to human operators facilitates informed decision-making, contributing to effective firefighting strategies. Firefighting robots stand as valuable tools in improving overall safety and response times during emergency situations, showcasing the potential for technology to complement and enhance traditional firefighting efforts.

## FUTURE SCOPE

**AI Integration:** Incorporating advanced artificial intelligence (AI) algorithms for improved decision-making and autonomy in firefighting scenarios.

**Sensor Innovations:** Advancements in sensor technologies, such as enhanced thermal imaging, gas detection, and environmental monitoring, to improve situational awareness for firefighting robots.

**Energy Efficiency:** Developing more energy-efficient systems and exploring alternative power sources to extend the operational time of firefighting robots.

**Communication Improvements:** Enhancing communication capabilities for better coordination between firefighting robots and with central command systems.

**Human-Robot Collaboration:** Integrating features that allow firefighting robots to collaborate effectively with human firefighters, providing support in challenging environments.

## REFERENCES

- [1] T. Sivakumar, K. Thamizhiniyan, "IoT based Fire Fighting Robot using Raspberry Pi," 2017 International Conference on Intelligent Computing and Control Systems (ICICCS).
- [2] S. S. Mathankumar, R. Nandhini, "Design and Implementation of IoT Based Fire Fighting Robot," International Journal of Engineering and Technology (IJET), Volume 8, No. 5.33, 2019.
- [3] S. S. Bhatia, R. R. Mudholkar, "An IoT-based Fire Fighting System using Arduino," 2018 International Conference on Current Trends towards Converging Technologies (ICCTCT).
- [4] M. N. Nithin, S. K. Arivazhagan, "Development of an IoT based Fire Fighting Robot," 2018 International Conference on Innovations in Information, Embedded and Communication Systems (ICIIECS).
- [5] A. N. Suryawanshi, A. B. Jadhav, "IoT Based Fire Fighting Robot Using NodeMCU," 2019 International Conference on Computing, Communication, and Automation (ICCCA).
- [6] K. B. Yogesh, K. S. Thippeswamy, "IoT Enabled Fire Fighting Robot for Industrial Applications," 2018 International Conference on Electrical, Electronics, Communication, Computer Technologies and Optimization Techniques (ICEECCOT).
- [8] K. S. Rajasekaran, V. S. Nithish, "Smart Fire Fighting Robot with IoT Integration," 2019 International Conference on Intelligent Sustainable Systems (ICISS).