

DESIGN AND IMPLEMENTATION OF IOT BASED ENERGY MANAGEMENT SYSTEM WITH DATA AQUISITION

Mr. CH. SATISH¹, A. PRANAY CHAND², Y. HARSHITHA³

¹Assistant Professor Dept. of ECE, PRAGATI ENGINEERING COLLEGE

²³UG Students, Dept. of ECE, PRAGATI ENGINEERING COLLEGE

ABSTRACT

An excellent amount of energy is wasted because of the dearth of smart management systems in home and office. Researchers are attempting to reduce the energy waste in many ways. The main target is added to avoid these varieties loss using a “IoT base smart controlling system” in home and office which has controlled light, fan, air-conditioner, and other electronic devices. So that introducing a new smart controller. This proposed project will be given priority in controlling during this stage to control electric device in home or office by daily companion of smartphone by android application at the identical time.

The proposed system is to possible see the important time data of energy consumption for each device which can mentally force us to prevent wasting in a fun way. This controlling network is the global network once outside home so we'll be able to control the device from anywhere within the world but after receiving the communication network is that the local hotspot network. So don't need the internet. Next, include an automation algorithm to the system (where light and fan will off or on with strength, temperature & humidity) which is able to make a decision whether a tool will on or off by using different quiet sensors.

This may make it a lot easier to cut back the waste and smart control of electric device. Finally, going to develop a synthetic intelligence algorithm in the system where every data of energy consumption will be stored in an excel sheet.

INTRODUCTION

Energy consumption is increasing rapidly with the increasing world population thus we are becoming more dependent on electronic devices. This heavy consumption of electric energy increases the demand of energy. This exponential growing demand for energy makes us realize the smart use of energy utilizing every bit of it. So, we need a smart energy management system to utilize our valuable energy. Here comes an Idea of a smart controller for a home energy

management system which will help an energy consumer to control home or office equipment by a simple means. By this system, energy will be used smartly so the energy waste will be reduced dramatically. Energy can be saved if there exists a network between electric devices, sensors, and other equipment. Through the network, which communicate with each other and will be able to save energy. To build the network we use the IoT.

Here things mean all the devices that can be connected to the internet while they can exchange data with each other, send or receive to any other devices that are part of these things. The user can also send the command through this network by the end user gateway.

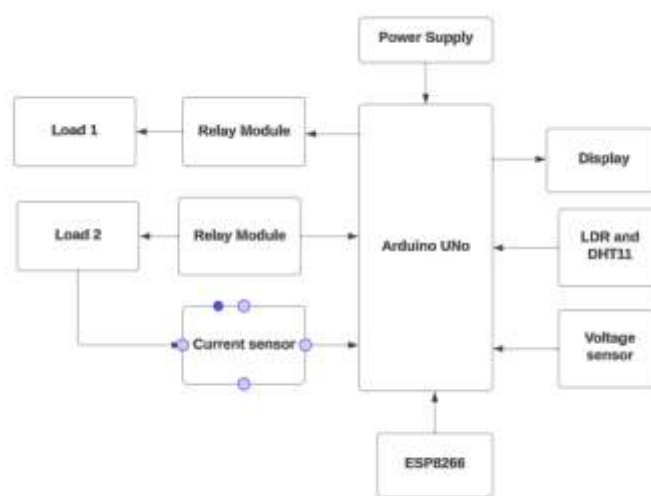

Figure.1 Block diagram

Objective of the Project

Real-time data acquisition: Develop a system that seamlessly collects real-time energy consumption data from various sources, including smart meters, sensors, and connected appliances. This may involve integrating with existing infrastructure or deploying new sensing units.

Comprehensive data analysis: Analyze the acquired data to understand energy usage patterns, identify peak consumption periods, and analyze appliance-level energy consumption. This may involve implementing data visualization tools and employing machine learning techniques for insights generation.

Energy optimization: Leverage the data analysis to develop strategies for optimizing energy consumption. This may involve implementing automated control mechanisms for appliances, scheduling energy-intensive tasks during off-peak hours, and providing real-time feedback to users for behavioral changes.

PROPOSED SYSTEM

In the proposed system which is being created, the energy management is done by the means of Iot devices which help in monitoring the over energy consumption and also gives the appropriate signals to the sensors to maintain the energy balance in the workplace or houses.

Design and implement an intelligent energy management system using the Internet of Things (IoT) technology for efficient data acquisition, monitoring, and analysis, leading to optimized energy consumption and cost reduction.

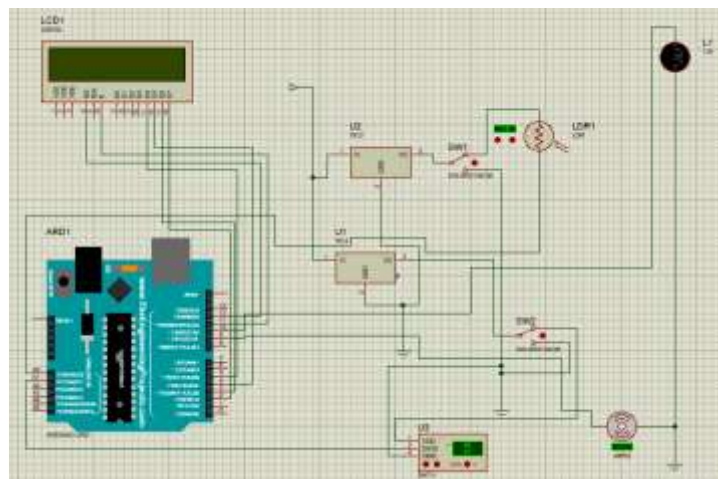

Figure.2 Schematic Diagram

RESULTS



Figure.3 Values on the LCD

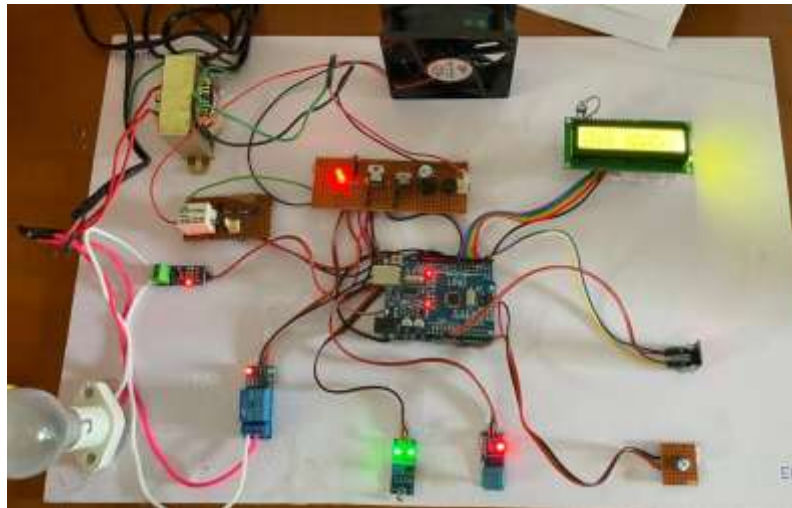

Figure.4 Real time connections with initial boot



Figure.5 Dashboard for real time analysis using "ThingSpeak"

CONCLUSION

This project successfully designed and implemented an IoT-based energy management system utilizing various sensors and data acquisition techniques. The key achievements are summarized below:

Comprehensive data collection: The system effectively collects real-time energy consumption data through diverse sensors, including current and voltage sensors, smart meters,

and environmental sensors. This data provides valuable insights into energy usage patterns and potential optimization opportunities.

Robust communication network: The implemented communication network reliably transmits sensor data to the central processing unit, ensuring continuous system operation and data integrity. This network can be adapted to various communication protocols and technologies based on specific requirements.

Automated control mechanisms: The system demonstrates the ability to implement automated control mechanisms based on pre-defined rules or machine learning algorithms. This enables dynamic adjustments to optimize energy usage and achieve cost savings.

FUTURE SCOPE

The future scope of this project can be extended by the following methods:

Increased personalization and user insights: Develop personalized energy recommendations based on individual usage patterns and behavioral analysis. Integrate with smart assistants for voice-activated control and feedback. Implement adaptive learning algorithms that optimize energy use based on real-time data and user preferences.

Enhanced grid integration and flexibility: Explore demand response participation with local utilities, allowing the system to adapt to grid fluctuations and optimize energy costs. Integrate with renewable energy sources like solar and wind power for efficient grid management and self-sufficiency. Develop peer-to-peer energy trading capabilities within communities for efficient energy sharing and cost reduction.

Expansion to larger scales and complex environments: Adapt the system for industrial and commercial applications in factories, buildings, and campuses. Explore urban-scale deployments for smart city initiatives and grid optimization. Integrate with building management systems (BMS) for comprehensive energy control and monitoring.

Focus on security and data privacy: Implement robust cybersecurity measures to protect sensitive data and prevent unauthorized access. Develop transparent data privacy policies and user consent mechanisms. Integrate with blockchain technology for secure and tamper-proof data storage and transactions.

REFERENCES

1. "Internet of Things (IoT) based Smart Energy Management System" by S. Ushakumari, K. N. Sheshadri, et al. (Published in Procedia Computer Science, 2018)
2. "Design and Implementation of Smart Energy Management System Based on IoT" by V. Palaniappan, S. Ramalingam, et al. (Published in International Journal of Engineering and Advanced Technology, 2019)
3. "Internet of Things (IoT): Technologies, Applications, Challenges, and Solutions" by B. S. Harish and D. Shraddha (Published by CRC Press, 2019)
4. "IoT Fundamentals: Networking Technologies, Protocols, and Use Cases for the Internet of Things" by David Hanes, Gonzalo Salgueiro, and Patrick Grossetete (Published by Cisco Press, 2017)
5. Proceedings of the International Conference on Internet of Things and Big Data (IoTBD), where research on IoT-based energy management systems and data acquisition techniques is often presented.
6. Proceedings of the IEEE International Conference on Industrial IoT and Smart Manufacturing (IoTSM), which may feature papers on IoT applications for energy management in industrial settings.
7. Articles and whitepapers published by IoT solution providers and energy management companies may offer insights into the implementation of IoT-based energy management systems. Companies such as Siemens, Schneider Electric, and Honeywell often publish resources on IoT applications in energy management.
8. GitHub and similar platforms host open-source projects related to IoT-based energy management systems. Exploring repositories and projects in this domain can provide practical insights and code examples for implementing such systems.
9. Reports and initiatives from energy regulatory bodies or government agencies focused on energy efficiency and sustainability may include case studies or guidelines for implementing IoT-based energy management systems.