

## IOT BASED DISASTER RESPONSE ROBOT

Mr. JOHN SAIDA SHAIK<sup>1</sup>, KALLA HEMA DURGA MANIKANTA<sup>2</sup>, PARTHAMSETTI  
RAMALAKSHMI<sup>3</sup>

<sup>1</sup>Assistant Professor, Dept. of ECE, PRAGATI ENGINEERING COLLEGE

<sup>23</sup>UG Students, Dept. of ECE, PRAGATI ENGINEERING COLLEGE

### ABSTRACT

According to National Crime Records Bureau (NCRB), it is estimated that more than 1.2 lakh deaths have been caused because of fire accidents in India from 2010-2014. Even though there are a lot of precautions taken for Fire accidents, these natural/man-made disasters do occur now and then. In the event of a fire breakout, to rescue people and to put out the fire we are forced to use human resources which are not safe. With the advancement of technology especially in Robotics it is very much possible to replace humans with robots for fighting the fire. This would improve the efficiency of firefighters and would also prevent them from risking human lives. Today we are going to build an IoT based Disaster Response Robots, which will automatically sense the fire and alive Human update the data on to BLYNK server and control the robot and start the water pump.

### INTRODUCTION

In times of calamity, whether wrought by nature's fury or human error, rapid and efficient response is paramount to saving lives and minimizing destruction. Traditional methods of disaster management often face limitations, particularly in accessing hazardous or inaccessible areas swiftly and safely. In this context, the emergence of IoT-based Disaster Response Robots heralds a new era in disaster relief efforts.

Equipped with an array of sensors and communication modules, these robots possess the ability to navigate treacherous terrains autonomously or under remote control. Advanced sensors, including cameras, LiDAR, and thermal imaging, provide real-time data on the disaster site, enabling the robots to assess hazards such as fires, gas leaks, or structural damage. Such capabilities are invaluable in providing crucial insights to first responders and decision-makers.

Communication modules integrated into these robots facilitate seamless coordination between on-site robots, command centers, and human responders. This interconnectedness ensures a

collaborative approach to disaster management, allowing for the swift dissemination of information and efficient allocation of resources. One of the primary applications of IoT-based Disaster Response Robots lies in search and rescue operations. These robots can navigate through rubble piles, collapsed buildings, and other hazardous environments to locate and extract survivors quickly and safely. Their autonomous navigation systems, coupled with manipulator arms for object retrieval, enable them to reach areas inaccessible to human responders, thereby increasing the chances of survival for those trapped in precarious situations.

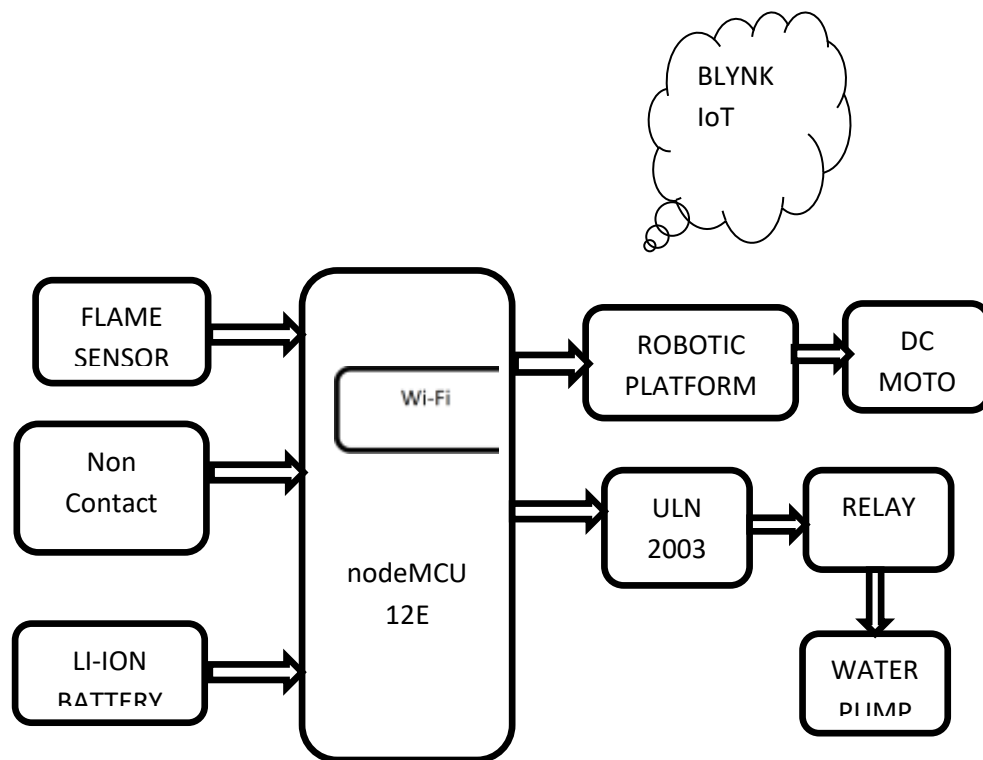

Figure.1 Block Diagram

### OBJECTIVE OF THE PROJECT

The objective of this project is to mitigate the risks associated with fire incidents by deploying an innovative solution that utilizes robotics and IoT technology to assist firefighters in extinguishing fires. With fire accidents becoming increasingly common, whether caused by human intervention or natural factors, it is imperative to enhance the capabilities of firefighting teams while reducing their exposure to dangerous environments.

Specifically, the project aims to achieve the following objectives:

Develop a robotic system capable of detecting fires autonomously in various environments, including hazardous locations such as nuclear power plants, petroleum refineries, and gas tanks.

Integrate IoT technology, specifically nodeMCU and Blynk server, to enable real-time communication and data updates when a fire is detected. This includes transmitting fire alerts to firefighting teams and controlling the robotic system remotely.

Implement functionality within the robotic system to navigate and maneuver through small, cramped areas and obstacles commonly encountered during firefighting operations. This includes exploring building ruins and overcoming high barriers to access fire-affected areas.

### LITERATURE SURVEY

#### **Define Your Keywords and Search Strategy:**

Start by defining the keywords related to your topic. These could include "IoT," "disaster response," "robotics," "emergency management," etc.

Utilize academic databases like IEEE Xplore, ScienceDirect, ACM Digital Library, and Google Scholar. Combine your keywords using Boolean operators (AND, OR) to refine your search results.

#### **Review Relevant Academic Papers:**

Look for academic papers, conference proceedings, and journal articles related to IoT-based disaster response robots. Pay attention to recent publications (last 5-10 years) to ensure you're capturing the latest advancements in the field.

**Explore Key Journals and Conferences:** Identify key journals and conferences in robotics, IoT, and disaster management. Examples include IEEE Transactions on Robotics, International Journal of Disaster Risk Reduction, IEEE International Conference on Robotics and Automation, etc.

Search within these platforms for relevant papers and articles.

#### **Analyze Existing Solutions and Technologies:**

Examine the methodologies, algorithms, and technologies employed in existing IoT-based disaster response robots. Look for common trends, challenges, and innovative approaches in the literature.

**Identify Gaps and Challenges:**

Assess the limitations and challenges faced by current IoT-based disaster response robots. Identify any gaps in the literature where further research is needed.

**PROPOSED SYSTEM**

This project differs from existing firefighting solutions by combining robotics, IoT technology, and autonomous capabilities to detect and extinguish fires in hazardous environments. Unlike traditional methods reliant on manual intervention, this system operates independently, minimizing risks to firefighters and enhancing efficiency in firefighting operations, especially in inaccessible or dangerous areas

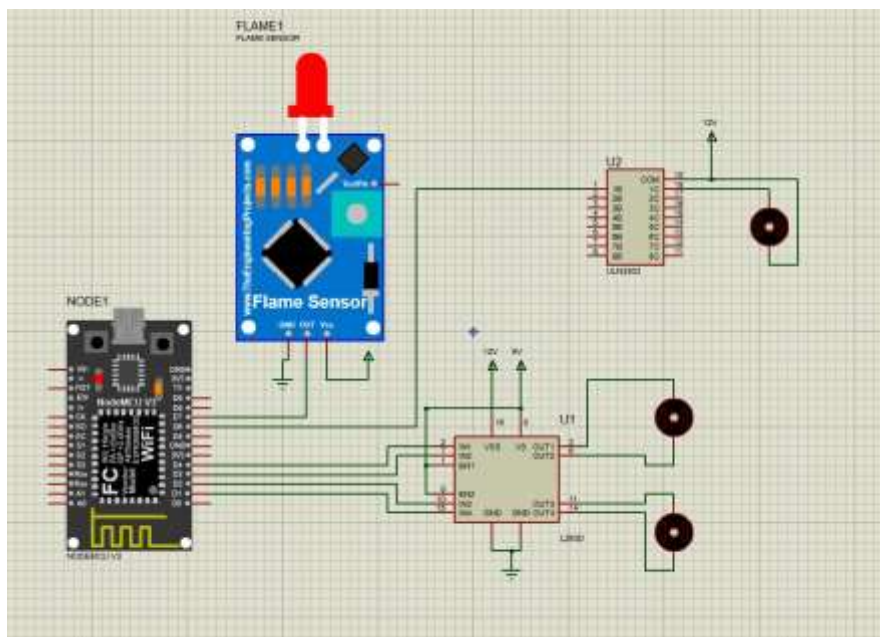

Figure.2 Schematic Diagram

RESULTS



Figure.3 Components



Figure.4 Power Supply

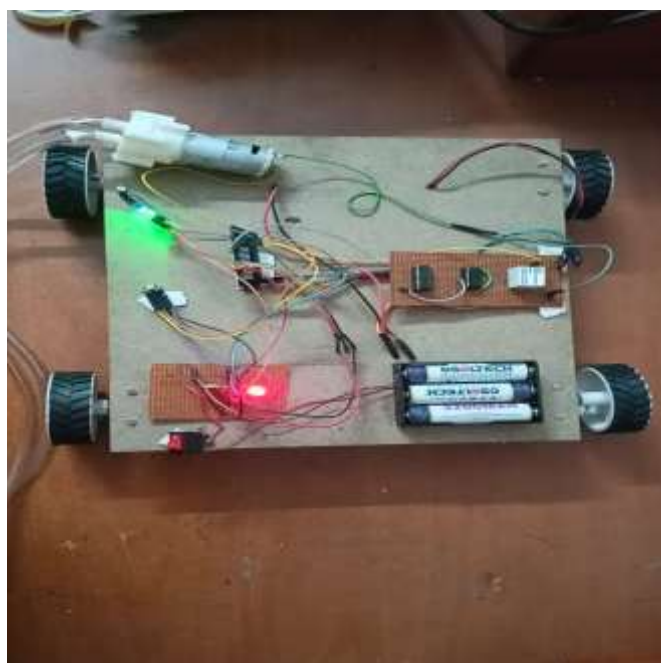

Figure.6 Practical working

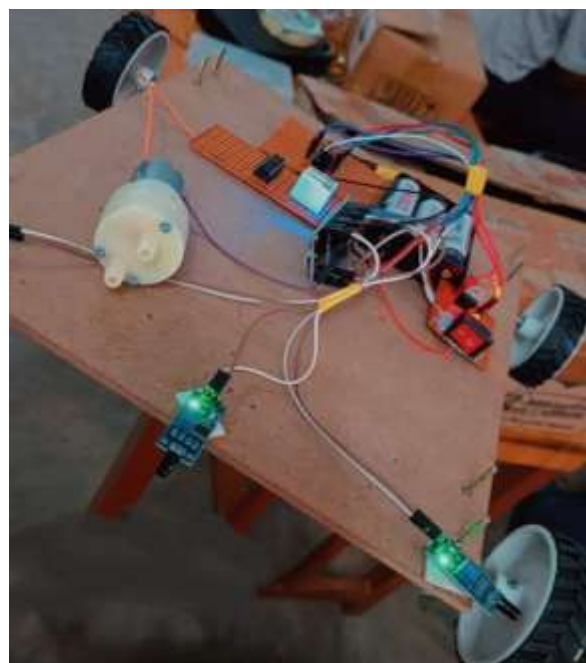

Figure.7 Working Kit

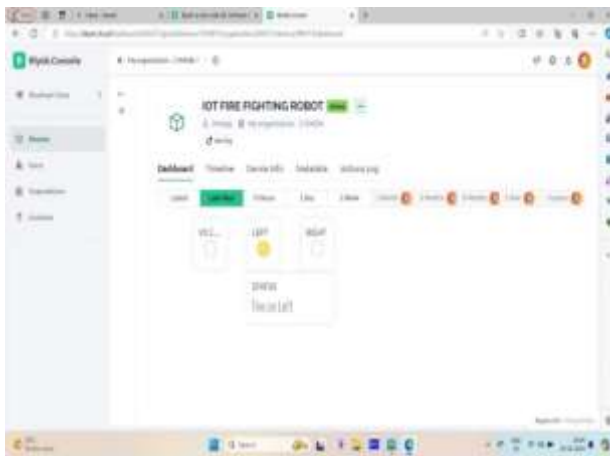

Figure.7 Status Fire on Left



Figure.8 Status Fire on Right

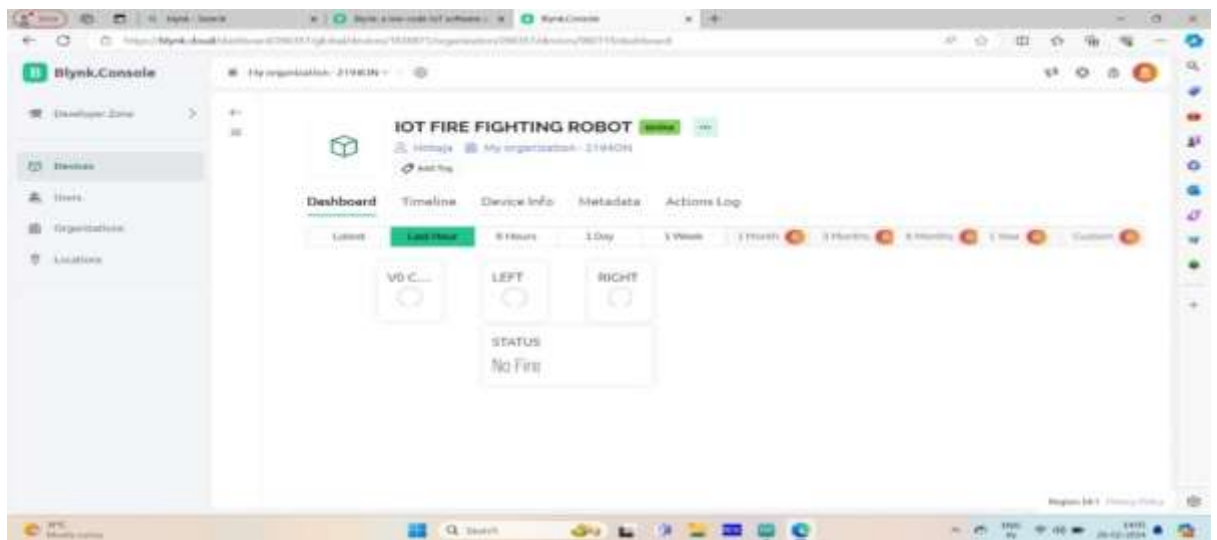

Figure.9 Status No fire

## CONCLUSION

In conclusion, the development of our firefighting vehicle incorporating advanced technologies such as the node MCU, flame sensor, DC water pump, and integration with the Blynk server represents a significant leap forward in firefighting capabilities. By harnessing the power of IoT and real-time data transmission, our vehicle offers enhanced responsiveness and efficiency in combating fires.

The node MCU enables seamless connectivity and control, allowing for remote monitoring and operation of the vehicle's functions. The inclusion of a flame sensor enhances safety by providing early detection of fires, enabling prompt intervention to mitigate risks effectively.

Furthermore, the integration of a DC water pump ensures reliable water supply for firefighting efforts, while the ability to upload data to the Blynk server facilitates comprehensive data analysis and optimization of firefighting strategies.

In essence, our firefighting vehicle stands at the forefront of innovation, poised to revolutionize firefighting operations by leveraging cutting-edge technology to safeguard lives and property. As we continue to refine and enhance its capabilities, we are committed to delivering a safer and more resilient future for communities worldwide.

## REFERENCES

1. F. Amigoni, N. Basilico, N. Gatti, and M. Mamei, "Fire-fighting robot teams for industrial applications," *Robotics and Autonomous Systems*, vol. 56, no. 11, pp. 915-930, 2008.
2. G. Lee, S. Kim, and S. Oh, "Design of a firefighting robot using water mist for fire suppression," *Robotics and Autonomous Systems*, vol. 61, no. 4, pp. 425-434, 2013.
3. R. Vanegas, L. J. Manso, R. Fernandez, and J. R. Martinez-de Dios, "Autonomous firefighting robots: Conceptual design, modelling, and control," *Robotics and Computer-Integrated Manufacturing*, vol. 29, no. 2, pp. 260-270, 2013.
4. R. He, F. Xiao, Y. Yang, and D. He, "A review of firefighting robot technology," *Fire Technology*, vol. 54, no. 2, pp. 427-449, 2018.
5. C. Y. Yang, Y. Y. Cheng, Y. H. Wu, and C. L. Yang, "An intelligent robotic system for fire-fighting applications in tunnel environments," *Automation in Construction*, vol. 102, pp. 30-42, 2019.
6. A.G. Smith and S. F. Smith, "Firefighting Robots: A Review of the State-of-the-Art," *Journal of Sensors*, vol. 2019, Article ID 4048531, 16 pages, 2019.
7. M. Yilmaz and M. Terzi, "Design of a fire extinguishing robot," *Journal of Theoretical and Applied Mechanics*, vol. 57, no. 3, pp. 859-871, 2019.
8. S. A. Ahmed, W. A. Mousa, and E. A. Abdelkader, "Firefighting Robot: Review and Future Perspectives," *International Journal of Advanced Robotic Systems*, vol. 17, no. 1, 2020.