

## **SMART GAS BOOKING SYSTEM AND LEAKAGE DETECTION USING IOT**

Mr. P.SRI SURESH<sup>1</sup>, M. LIKHITHA<sup>2</sup>, K.SAI MURALI KRISHNA<sup>3</sup>

<sup>1</sup>Assistant Professor, Dept. of ECE, PRAGATI ENGINEERING COLLEGE

<sup>23</sup>UG Students, Dept. of ECE, PRAGATI ENGINEERING COLLEGE

### **ABSTRACT**

Liquefied Petroleum Gas (LPG) is the essential fuel that has been utilized in cooking ovens. Because of the deficiency of LPG creation in India, the stock of LPG through the pipeline has been not yet settled. This framework is advantageous so that the LPG client could identify the spillage of gas during coincidental conditions and furthermore measure how much gas extra is in the chamber.

The most common problem experienced in our day- to- day lives that is regarding GAS container going empty. We bring this paper to create awareness about the reducing weight of the gas in the container, and to place a gas order using IOT. The gas booking/order is being done with the help IOT and that the continuous weight measurement is done using a load cell which is interfaced with a Microcontroller (to compare with an ideal value). When it comes to security of the kit as well as gas container we have an MQ series gas sensor, LM 35 (temperature sensor), which will detect the surrounding environment for any chance of error. Whenever any change is subjected in any of the sensors (load cell, LM35, MQ) an alarm is triggered. And the same information will be uploaded to the IOT cloud platform to send notifications.

### **INTRODUCTION**

A smart gas booking system and leakage detection using IoT (Internet of Things) revolutionizes the traditional process of gas management by seamlessly integrating advanced technologies to enhance efficiency, convenience, and safety measures.

At its core, this system employs a network of IoT devices, including sensors and actuators, strategically placed within gas cylinders or along pipelines to monitor various parameters such as gas levels, pressure, temperature, and humidity in real-time. These sensors continuously

collect data and transmit it to a central control unit or a cloud-based platform for analysis and processing.

One of the key features of this system is its smart gas booking functionality. By leveraging IoT technology, users can easily monitor their gas consumption remotely through a dedicated mobile app or web portal. The system provides real-time updates on gas levels and predicts when a refill will be needed based on consumption patterns and historical data. This proactive approach eliminates the inconvenience of manual monitoring and ensures that users never run out of gas unexpectedly.

Moreover, the IoT-enabled leakage detection component of the system enhances safety by constantly monitoring for any abnormal gas leakage patterns. In the event of a potential leak, the sensors immediately detect the anomaly and trigger alerts to notify both the user and the gas service provider. These alerts can be delivered via SMS, email, or push notifications, allowing for swift response and mitigation of the leak to prevent potential hazards such as fire or environmental damage.

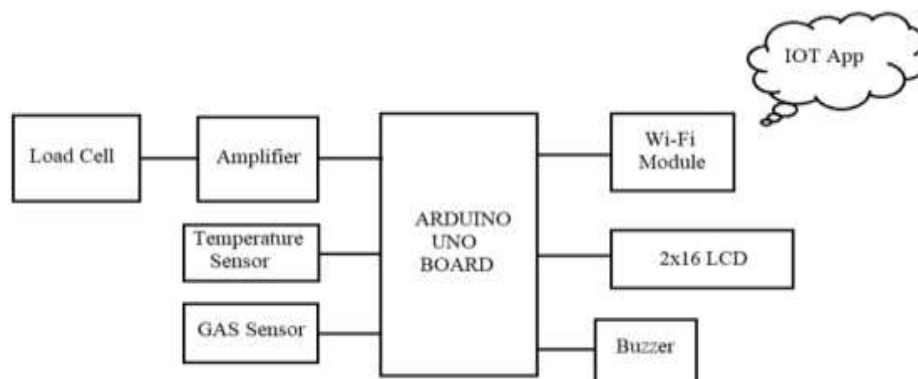

Figure.1 Block diagram

### OBJECTIVE OF THE PROJECT

The objective of implementing a smart gas booking system and leakage detection using IoT technologies encompasses several key aspects aimed at enhancing the overall efficiency, safety, and convenience of managing gas resources within both residential and commercial settings.

**Efficiency Enhancement:** By integrating IoT sensors and devices, the system aims to automate various processes involved in gas booking and monitoring. This automation reduces manual intervention, streamlines operations, and minimizes the chances of errors or delays in

scheduling gas refills. With the ability to monitor gas levels in real-time, users can optimize their consumption patterns and ensure timely refills, thus avoiding interruptions in gas supply.

**Convenience for Users:** The smart gas booking system offers users a convenient way to manage their gas supply remotely. Through IoT-enabled devices such as mobile applications or web portals, users can easily check their gas levels, schedule refills, and track the status of their bookings from anywhere at any time. This eliminates the need for manual monitoring or frequent physical inspections, providing users with greater control and flexibility over their gas consumption.

**Safety Measures:** One of the primary objectives of integrating leakage detection capabilities into the system is to enhance safety measures associated with gas usage. IoT sensors installed in gas pipelines or storage tanks continuously monitor for any signs of gas leaks. In the event of a leak, the system promptly detects it and triggers automated alerts to notify relevant stakeholders, such as homeowners, gas service providers, or emergency responders. This swift detection and response mechanism help mitigate the risk of potential accidents or hazards caused by gas leaks, safeguarding lives and property.

**Real-time Monitoring and Alerts:** Through the deployment of IoT sensors and connected devices, the system enables real-time monitoring of gas levels, consumption patterns, and potential leakages. Users receive instant notifications or alerts via mobile applications, email, or SMS in case of abnormal gas levels or leakages, allowing them to take immediate action. This proactive approach not only ensures timely intervention but also helps prevent escalation of safety incidents, thereby enhancing overall security and peace of mind for users.

**Data Analytics and Insights:** By gathering and analyzing data collected from IoT sensors and devices, the system generates valuable insights into gas consumption patterns, refill frequency, leak detection trends, and other relevant metrics. This data-driven approach enables stakeholders, including gas suppliers and regulatory authorities, to gain a deeper understanding of gas usage dynamics and make informed decisions regarding resource allocation, infrastructure maintenance, and safety regulations.

**Integration with Existing Infrastructure:** The smart gas booking system is designed to seamlessly integrate with existing gas infrastructure and management systems. Whether it's retrofitting IoT sensors onto existing pipelines or integrating with legacy booking and billing platforms, the system ensures compatibility and interoperability with various hardware and

software components. This interoperability enables smooth deployment and adoption of the system without disrupting existing operations or requiring significant infrastructure upgrades.

### **PROPOSED SYSTEM**

Gas level sensing and automatic booking are created with a variety of features that are implemented using ARDUINO, and this device will serve as a single system with different applications for LPG consumers. The device keeps track of the gas level load and displays it in the app. It also uses a gas sensor to detect gas leaks, and if one is detected, the Buzzer is activated and the user is notified through mobile. This includes the option of ordering a new LPG cylinder if the gas level drops to dangerously low levels. After that, it sends a mobile alert.

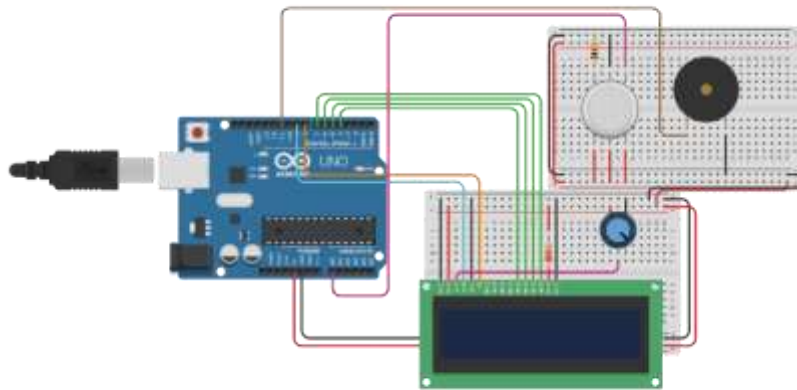

Figure.2 Schematic Diagram

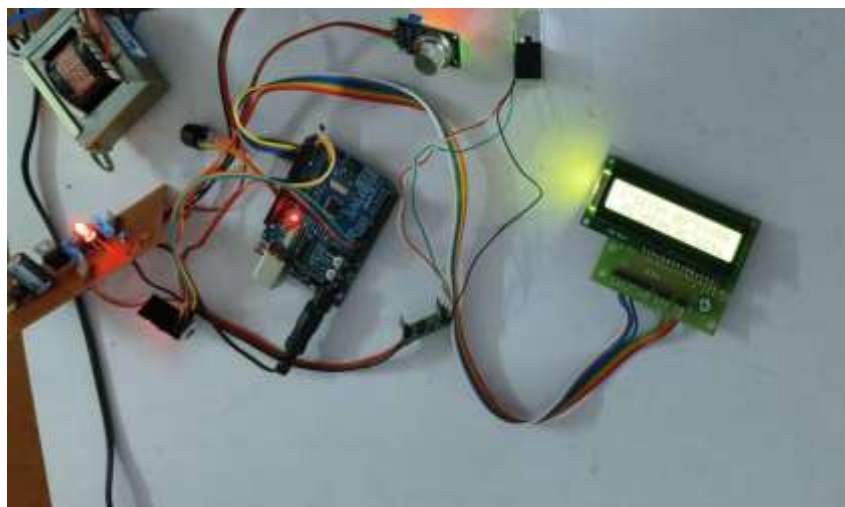

Figure.3 Working Kit

RESULTS



Figure.4 Paramter on status on thingspeak



Figure.5 parameters values diplaying on LCD

### APPLICATIONS

**Efficient Gas Management:** The system optimizes gas delivery schedules based on real-time consumption data, ensuring timely refills and reducing the risk of running out of gas.

**Cost Savings:** By accurately monitoring gas usage and detecting leakages promptly, the system helps in reducing wastage, thereby saving costs for both consumers and gas suppliers.

**Safety:** IoT sensors can detect gas leakages in real-time, triggering immediate alerts to users and gas suppliers. This timely detection prevents potential accidents and ensures safety.

**Remote Monitoring:** Users can monitor their gas consumption and detect leakages remotely through mobile applications or web interfaces, providing convenience and peace of mind.

### CONCLUSION

The main purpose here is to provide safety to the users of the LPG (Liquefied Petroleum Gas) in various fields like cooking, automobiles, industries, etc. Using this system we can easily monitor the amount of LPG present within the cylinder and also detect the LPG leakage and fire and alert the user and respective authorities immediately so that the assistance is provided as soon as possible. It uses various sensors such as MQ-2 sensor, Flame sensor and load cell to monitor the LPG being used completely to prevent accidents caused by carelessness or misuse of LPG. As the world is moving towards being smarter every day, we can integrate this system with other home automation systems for creating complete home automation and security systems which can be used in smart houses and smart cities, etc.

### FUTURE SCOPE

The future scope for Smart Gas Booking and Leakage Detection systems using IoT is promising, with several potential advancements and enhancements that can further improve efficiency, accuracy, and user experience. Integration of Smart Gas Booking systems with smart grid technologies for more efficient gas distribution, demand management, and load balancing. Utilization of real-time data from gas sensors to optimize gas distribution networks, reduce wastage, and improve overall energy efficiency.

Expansion of the system's capabilities to include environmental monitoring features, such as air quality monitoring and pollution detection, in addition to gas leakage detection.

Integration with environmental sensors to monitor pollutants, particulate matter, and greenhouse gas emissions for better environmental management and sustainability.

Development of dedicated mobile applications and IoT interfaces for seamless interaction with Smart Gas Booking and Leakage Detection systems.

Integration of features such as remote monitoring, real-time alerts, booking management, and user feedback mechanisms to enhance user convenience and engagement.

**REFERENCES:**

1.2T. Soundarya, J. Anchitaalagammai, G. D. Priya, and S. K. Kumar, “C-Leakage: Cylinder LPG Gas Leakage Detection for Home Safety,” IOSR Journal of Electronics and Communication Engineering, vol. 9, no. 1, pp. 53–58, 2014.

2. Ashish Shrivastava, Ratnesh Prabhaker, Rajeev Kumar and RahulVerma, Gsm Based Gas Leakage Detection System, International Journal of Technical Research and Applications e-ISSN: 2320-8163, Volume 1, Issue 2, 2013.

3. Srinivasan A., Leela N., Jeyabharathi V., Kirthika R and Rajasree, Gas Leakage And Detection Control, International Journal of Advance Engineering and Research Development Volume 2, Issue 3, @IJAERD- 2015, All rights Reserved 464 Scientific Journal of Impact Factor(SJIF): 3.134 e-ISSN(O): 2348-4470 p-ISSN(P): 2348-6406, 2015.

4. Arpitha, T. & Kiran, Divya & Gupta, V. & Duraiswamy, Punithavathi. (2016). FPGA-GSM based gas leakage detection system. 1-4. 10.1109/INDICON.2016.7838952.

5. Mahalingam, R. T. Naayagi, and N. E. Mastorakis. 2012. Design and implementation of an economic gas leakage detector. In Proceedings of the 11th international conference on Applications of Electrical and Computer Engineering (ACA'12). World Scientific and Engineering Academy and Society (WSEAS), Stevens Point, Wisconsin, USA, 20–24.

6. P.Meenakshi Vidya, S.Abinaya, G.Geetha Rajeswari, N.Guna ,“Automatic LPG detection and hazard controlling “ published in April 2014.

7. K.Padmapriya, Surekha, Preethi, “Smart Gas Cylinder Using Embedded System”, published in 2014.

8. C.Selvapriya, S.Sathyaprabha, M.Abdul rahim,” LPG leakage monitoring and multilevel alerting system”, published in 2013.