

BOREWELL WATER QUALITY AND MONITORING BASED IOT GATEWAY

Ms. RUBIA TASNEEM¹, T.V.S. NAGA JYOTHI², B. PRASANTH KUMAR³

¹Assistant Professor, Dept. of ECE, PRAGATI ENGINEERING COLLEGE

²³UG Students, Dept. of ECE, PRAGATI ENGINEERING COLLEGE

ABSTRACT

Water pollution is one of the biggest fears for the green globalization. In order to ensure the safe supply of the drinking water the quality needs to be monitor in real time. In this project we present a design and development of a low cost system for real time monitoring of the water quality in IOT tehnology methodology and water dispense system using motor pump. The system consist of several sensors is used to measuring contamination parameters of the water. The water quality is measured using turbidity sensor for contamination level (dirtiness) of water and also measuring the temperature of the motor pump using DHT sensor. The measured values from the sensors can be processed by the core controller. The ESP8266 based NodeMCU can be used as a core controller to read the values and upload those values to cloud server. Here Blynk IoT cloud server is used to monitor sensor values on web dash board / mobile app dash board.

INTRODUCTION

India is an agrarian country and farmers depend on groundwater. Due to the irregular distribution of rainfall and failure of monsoon, it led to forcefully drilling of borewell to greater depths. Since there is no alternative, the people in Urban areas depend on borewell water. Furthermore, water pollution has been an increased problem over the last few years. To overcome disadvantages like poor quality drinking water, increased manpower requirements, irreversible damage caused to poorly monitored public motors, technology advancements like Big Data, Internet of Things, Cloud Computing and Internet facility can be used to monitor the borewell. borewell are a vital source for the people. To implement this project, the system would use two sensors namely turbidity and DHT11 sensor to check water quality while the motor monitoring would be done by the temperature sensor.

Water is one of the most vital resources for sustaining life on Earth. However, in recent years, the quality of water has been increasingly threatened by various pollutants, posing significant challenges to human health and the environment. Pollution of water bodies occurs through the discharge of harmful substances, such as industrial waste, agricultural runoff, and household chemicals, into rivers, lakes, and groundwater sources. This essay delves into the causes and consequences of water pollution and explores how borewell water quality projects play a crucial role in detecting and monitoring contamination levels.

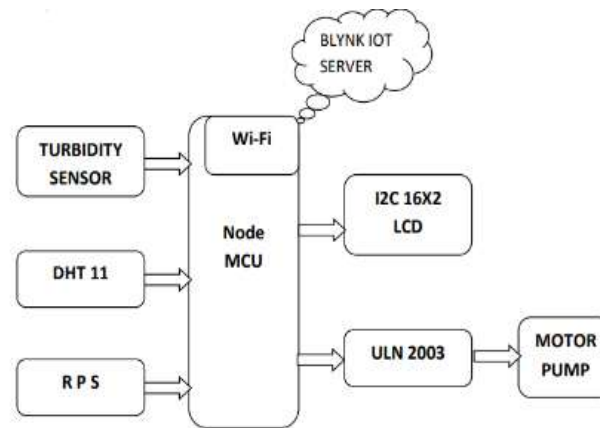

Figure.1 Block diagram

OBJECTIVE OF THE PROJECT

Monitor Water Quality: The project aims to continuously monitor the quality of water in borewell by collecting data on various parameters such as pH, turbidity, dissolved oxygen, and levels of contaminants like heavy metals and pesticides.

Early Detection of Contamination: By employing sensors and monitoring devices, the project seeks to detect contamination events in real-time, allowing for prompt intervention and mitigation measures to prevent further deterioration of water quality.

Localized and Decentralized Monitoring: The project aims to provide localized and decentralized monitoring solutions, particularly in remote and rural areas where access to clean water is limited and contamination risks are high.

PROPOSED SYSTEM

The main aim is to detect the WATER CONTAMINATION LEVEL remotely. It is very helpful when we want to use a water from underground, as we cannot see the water directly instead of that if we use this technique, then we can reduce the contamination water intake and can

decrease the environment pollution. When we ON the motor pump, it indicates the water quality and temperature in a server itself. We written a code for BLYNK server to access remotely. This is actually can operate through remotely also. The Turbidity value and temperature of a water will be shown in a LIQUID CRYSTAL DISPLAY. We keep the TURBIDITY SENSOR in a water for testing quality of a Water.

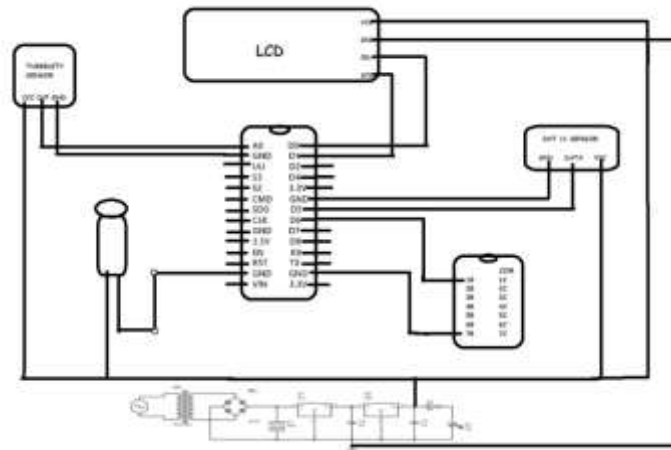

Figure.2 Schematic Diagram

RESULTS

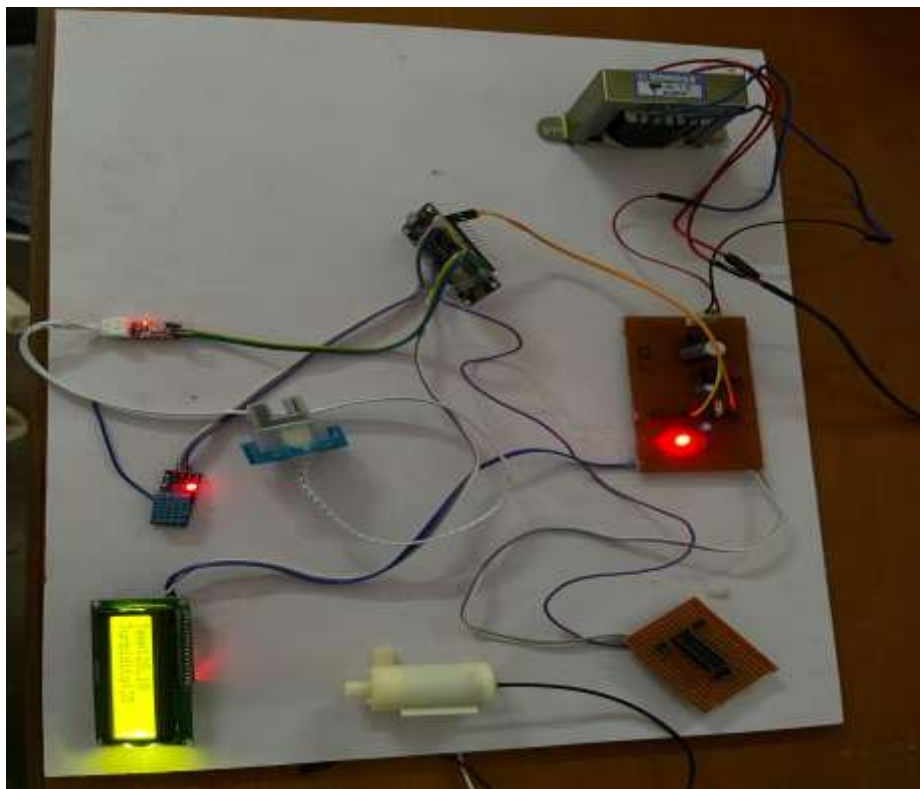

Figure.3 Displaying the values on LCD



Figure.4 Values on Blynk App

ADVANTAGES

- Seamless Communication
- Data Accuracy
- Early Detection of Contamination
- Cost Efficiency
- Remote Access and Control
- Environmental Conservation
- Improved Resource Management

APPLICATIONS

- Agriculture
- Industrial Use
- Drinking Water supply
- Environment Monitoring
- Ground Water Management
- Research and Education

CONCLUSION

In conclusion, the implementation of a borewell water quality monitoring system utilizing IoT gateway technology has demonstrated significant potential in ensuring real-time water quality assessment and management. Through the integration of sensors and data processing capabilities, this project offers a comprehensive solution for continuous monitoring, analysis, and remote management of borewell water quality parameters.

By harnessing the power of IoT, stakeholders can access timely and accurate information about water quality, enabling prompt decision-making and intervention to address any detected issues. This proactive approach to water quality management not only safeguards public health but also supports sustainable resource management practices.

Furthermore, the scalability and adaptability of this system allow for its deployment in various settings, ranging from individual households to community water supply networks. Its ability to provide actionable insights in real-time empowers users to take preventive measures and optimize resource utilization effectively.

As we continue to face challenges related to water scarcity and pollution, the integration of innovative technologies such as IoT-based water quality monitoring systems becomes increasingly crucial. This project serves as a testament to the potential of technology-driven solutions in addressing complex environmental challenges and underscores the importance of ongoing research and development in this field. Through collaborative efforts and continued innovation, we can strive towards a future where access to safe and clean water is ensured for all.

FUTURE SCOPE

In addition to the significant advancements achieved through the implementation of the borewell water quality monitoring system based on IoT gateway technology, there exists a promising future scope for further enhancements and applications.

One avenue for future development lies in the refinement of sensor technologies to enable even more precise and comprehensive monitoring of water quality parameters. This may include the integration of advanced sensors capable of detecting a broader range of contaminants or the development of miniaturized, low-cost sensors to facilitate widespread deployment.

Furthermore, advancements in data analytics and machine learning algorithms hold great potential for enhancing the predictive capabilities of the monitoring system. By analyzing historical data patterns and incorporating predictive models, the system could anticipate changes in water quality, enabling preemptive measures to mitigate potential risks or contamination events.

REFERENCE

1. **Published in:** 2018 International Conference on Communication, Computing and Internet of Things (IC3IoT) <https://ieeexplore.ieee.org/document/8668147> Published by panel
2. Varsha Lakshmikantha, Anjitha Hiriyannagowda, Akshay Manjunath, Aruna Patted, Jagadeesh Basavaiah IOT WATER QUALITY MONITORING SYSTEM in Received 1 June 2021, Accepted 2 July 2021, Available online 12 August 2021, Version of Record 1 November 2021.
3. Published as conference paper by sujitha karimisetty & Vaikunta rao raguda..Part of the Advances in Intelligent Systems and Computing book series (AISC, volume 1171)